

HDD/CD RECORDER

CDR-HD1000

SERVICE MANUAL

IMPORTANT NOTICE

This manual has been provided for the use of authorized YAMAHA Retailers and their service personnel. It has been assumed that basic service procedures inherent to the industry, and more specifically YAMAHA Products, are already known and understood by the users, and have therefore not been restated.

WARNING: Failure to follow appropriate service and safety procedures when servicing this product may result in personal injury, destruction of expensive components, and failure of the product to perform as specified. For these reasons, we advise all YAMAHA product owners that any service required should be performed by an authorized YAMAHA Retailer or the appointed service representative.

IMPORTANT: The presentation or sale of this manual to any individual or firm does not constitute authorization, certification or recognition of any applicable technical capabilities, or establish a principle-agent relationship of any form.

The data provided is believed to be accurate and applicable to the unit(s) indicated on the cover. The research, engineering, and service departments of YAMAHA are continually striving to improve YAMAHA products. Modifications are, therefore, inevitable and specifications are subject to change without notice or obligation to retrofit. Should any discrepancy appear to exist, please contact the distributor's Service Division.

WARNING: Static discharges can destroy expensive components. Discharge any static electricity your body may have accumulated by grounding yourself to the ground buss in the unit (heavy gauge black wires connect to this buss).

IMPORTANT: Turn the unit OFF during disassembly and part replacement. Recheck all work before you apply power to the unit.

■ CONTENTS

TO SERVICE PERSONNEL	1~2	FIRMWARE UPDATE PROCEDURES	12~13
PREVENTION OF ELECTRO STATIC DISCHARGE ...	2	HDD FORMAT	13
FRONT PANEL	3	DISPLAY DATA	14~15
REAR PANELS	3	IC DATA	16~24
REMOTE CONTROL TRANSMITTER PANEL	4	BLOCK DIAGRAM	25
SPECIFICATIONS	4	PRINTED CIRCUIT BOARD	26~33
INTERNAL VIEW	5	SCHEMATIC DIAGRAM	34~37
DISASSEMBLY PROCEDURES	5~7	PARTS LIST	38~47
SERVICE CHECK PROCEDURES	8~9	REMOTE CONTROL TRANSMITTER	48
INSPECTIONS	9~11		



このサービスマニュアルは、エコマーク認定の再生紙を使用しています。
This Service Manual uses recycled paper.

■ TO SERVICE PERSONNEL

1. Critical Components Information

Components having special characteristics are marked  and must be replaced with parts having specifications equal to those originally installed.

2. Leakage Current Measurement (For 120V Models Only)

When service has been completed, it is imperative to verify that all exposed conductive surfaces are properly insulated from supply circuits.

- Meter impedance should be equivalent to 1500 ohm shunted by 0.15 μ F.
- Leakage current must not exceed 0.5mA.
- Be sure to test for leakage with the AC plug in both polarities.

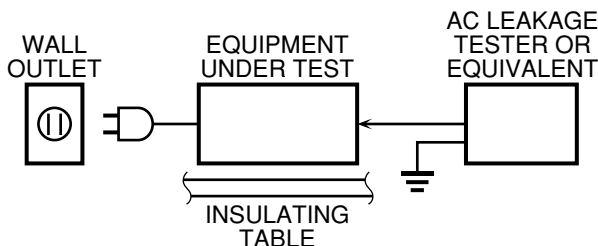

THE COMPACT DISC RECORDER SHOULD NOT BE ADJUSTED OR REPAIRED BY ANYONE EXCEPT PROPERLY QUALIFIED SERVICE PERSONNEL.

WARNING: CHEMICAL CONTENT NOTICE!

The solder used in the production of this product contains LEAD. In addition, other electrical/electronic and /or plastic (where applicable) components may also contain traces of chemicals found by the California Health and Welfare Agency (and possibly other entities) to cause cancer and/or birth defects or other reproductive harm.

DO NOT PLACE SOLDER, ELECTRICAL/ELECTRONIC OR PLASTIC COMPONENTS IN YOUR MOUTH FOR ANY REASON WHATSOEVER!

Avoid prolonged, unprotected contact between solder and your skin! When soldering, do not inhale solder fumes or expose eyes to solder/flux vapor!

If you come in contact with solder or components located inside the enclosure of this product, wash your hands before handling food.

WARNING: Laser Safety

This product contains a laser beam component. This component may emit invisible, as well as visible radiation, which may cause eye damage. To protect your eyes and skin from laser radiation, the following precautions must be used during servicing of the unit.

- 1) When testing and/or repairing any component within the product, keep your eyes and skin more than 30 cm away from the laser pick-up unit at all times. Do not stare at the laser beam at any time.
- 2) Do not attempt to readjust, disassemble or repair the laser pick-up, unless noted elsewhere in this manual.
- 3) CAUTION: Use of controls, adjustments or performance of procedures other than those specified herein may result in hazardous radiation exposure.

Laser Emitting conditions:

1. This device is a Class IIIb laser device **when the protective case is removed.**

Class IIIb means

The output is such that exposure to the light from the laser, either directly or reflected by a mirror, can cause harm to the eyes, but that there is no danger to the eyes from exposure to dispersed reflected laser light. (Generally 0.5 W or less)

2. Always wear eyeglasses designed for protection against laser light.
3. Always wear gloves.
4. Have no reflective objects anywhere near this device.
5. Figure A shows from where in this device the laser is emitted.
6. When switching on the power to the device for the first time, always measure the laser power with a laser power meter and check that the power is no greater than the number of Watts in the specifications.
7. Never look directly at the laser light while the laser is emitting light.
8. Do not allow the laser light to shine directly on your skin while the laser is emitting light.

PROTECTION OF EYES FROM LASER BEAM DURING SERVICING

This set employs a laser. Therefore, be sure to carefully follow the instructions below when servicing.

1. Laser Diode Properties

- Material : GaAlAs
- Wavelength : 780-787 nm
- Emission Duration : Pulse
- Laser Output : Read mode 0.7mW (Continuous) *
Write mode max. 38mW *
(for 166ns, Min. Cycle 86.6ns)

* This output is the value measured at the lens of the Laser Pickup Unit.

2. When checking the laser diode emission, keep your eyes more than 30 cm away from the objective lens.

VARO!: AVATTAESSA JA SUOJALUKITUS OHITETTAESSA OLET ALTTIINA NÄKYMÄTÖMÄLLE LASER-SÄTEILYLLE. ÄLÄ KATSO SÄTEESEEN.

WARNING!: OSYNLIG LASERSTRÅLNING NÄR DENNA DEL ÄR ÖPPNAD OCH SPÄRREN ÄR URKOPPLAD. BETRakta EJ STRÅLEN.

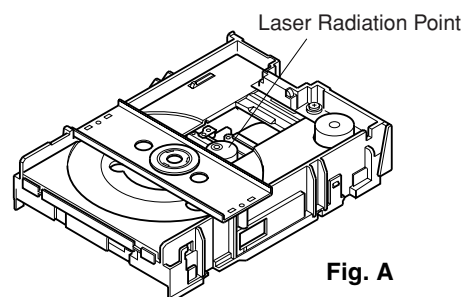

Fig. A

CAUTION - VISIBLE AND / OR INVISIBLE LASER RADIATION WHEN OPEN. AVOID EXPOSURE TO BEAM.

VARNING - SYNLIg OCH / ELLER OSYNLIg LASERSTRÅLNING NÄR DENNA DEL ÄR ÖPPNAD. STRÅLEN ÄR FARLIG.

VARO! AVATTAESSA OLET ALTTIINA NÄKYMÄLLE JA / TAI NÄKYMÄTÖMÄLLE LASERSÄTEILYLLE. ÄLÄ KATSO SÄTEESEEN.

VARNING - SYNLIg OCH / ELLER OSYNLIg LASERSTRÅLNING NÄR DENNA DEL ÄR ÖPPNAD. BETRakta EJ STRÅLEN.

VORSICHT! SICHTBARE UND / ODER UNSICHTBARE LASERSTRALUNG WENN ABDECKUNG BEÖFFNET. NICHT DEM STRAHL AUSSETZEN.

ATTENTION - RADIATION VISIBLE ET / OU INVISIBLE LORSQUE L'APPAREIL EST OUVERT. EVITEZ TOUTE EXPOSITION AU FAISCEAU.

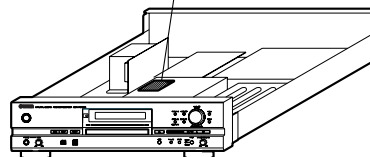

■ PREVENTION OF ELECTRO STATIC DISCHARGE

Some semiconductor (solid state) devices can be damaged easily by static electricity. Such components commonly are called Electrostatically Sensitive (ES) Devices. Examples of typical ES devices are integrated circuits and some field-effect transistors and semiconductor "chip" components. The following techniques should be used to help reduce the incidence of component damage caused by electro static discharge (ESD).

1. Immediately before handling any semiconductor component or semiconductor-equipped assembly, drain off any ESD on your body by touching a known earth ground. Alternatively, obtain and wear a commercially available discharging ESD wrist strap, which should be removed for potential shock reasons prior to applying power to the unit under test.
2. After removing an electrical assembly equipped with ES devices, place the assembly on a conductive surface such as aluminum foil, to prevent electrostatic charge buildup or exposure of the assembly.
3. Use only a grounded-tip soldering iron to solder or unsolder ES devices.
4. Use only an anti-static solder removal device. Some solder removal devices not classified as "anti-static (ESD protected)" can generate electrical charge sufficient to damage ES devices.
5. Do not use freon-propelled chemicals. These can generate electrical charges sufficient to damage ES devices.
6. Do not remove a replacement ES device from its protective package until immediately before you are ready to install it. (Most replacement ES devices are packaged with leads electrically shorted together by conductive foam, aluminum foil or comparable conductive material).
7. Immediately before removing the protective material from the leads of a replacement ES device, touch the protective material to the chassis or circuit assembly into which the device will be installed.
CAUTION: Be sure no power is applied to the chassis or circuit, and observe all other safety precautions.
8. Minimize bodily motions when handling unpackaged replacement ES devices. (Otherwise harmless motion such as the brushing together of your clothes fabric or the lifting of your foot from a carpeted floor can generate static electricity (ESD) sufficient to damage an ES device).

Grounding for electrostatic breakdown prevention

1. Human body grounding
Use an anti static wrist strap to discharge the static electricity from your body.
2. Work table grounding
Put a grounded conductive material (sheet) or iron sheet on the area where the optical pickup is placed.

Caution:

The static electricity of your clothes will not be grounded through the wrist strap. So take care not to let your clothes touch the optical pickup.

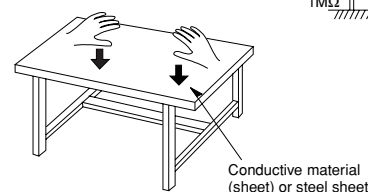
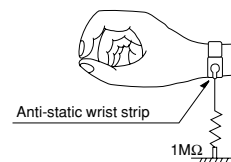

FRONT PANEL

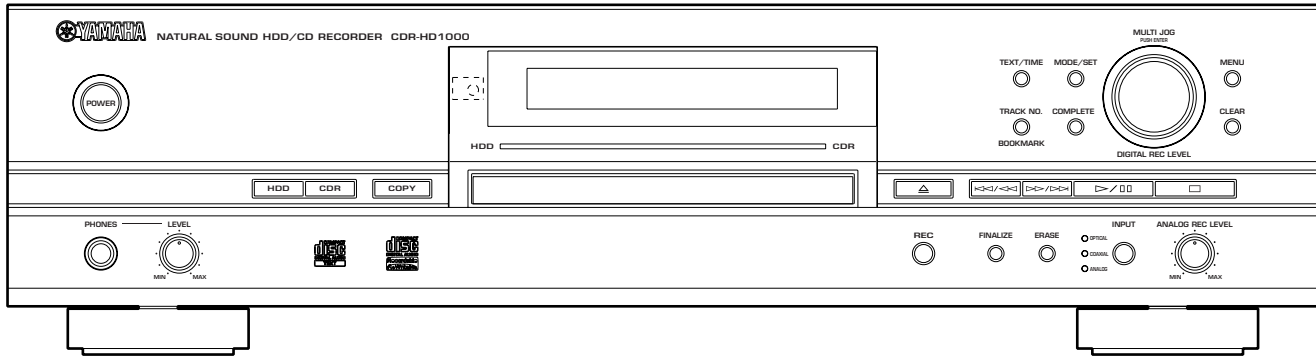

REAR PANELS

U, C models

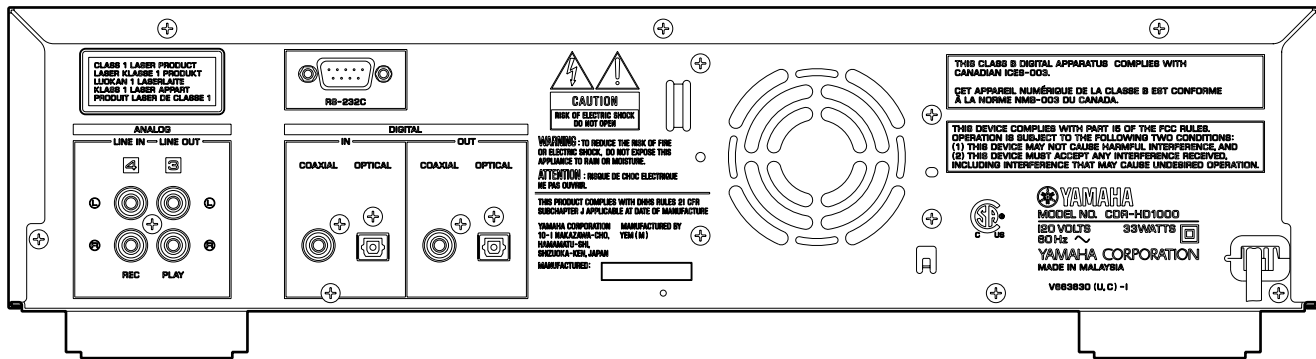

A model

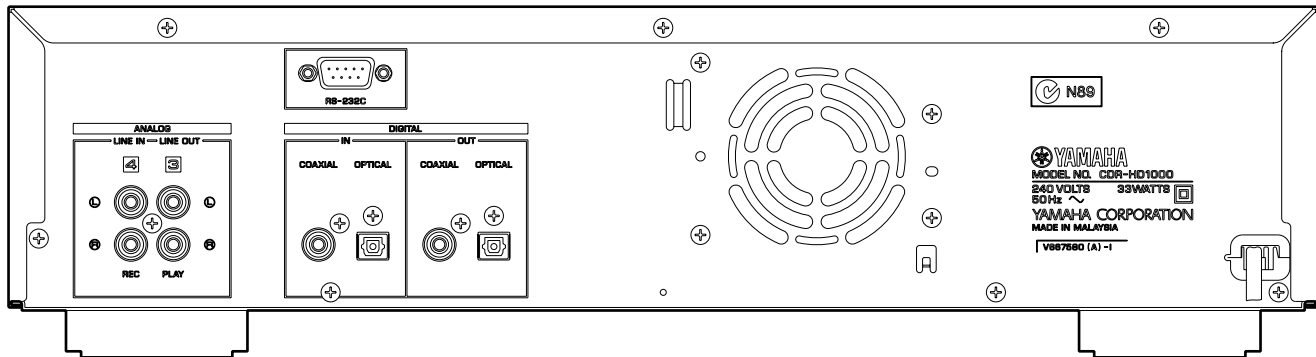

G model

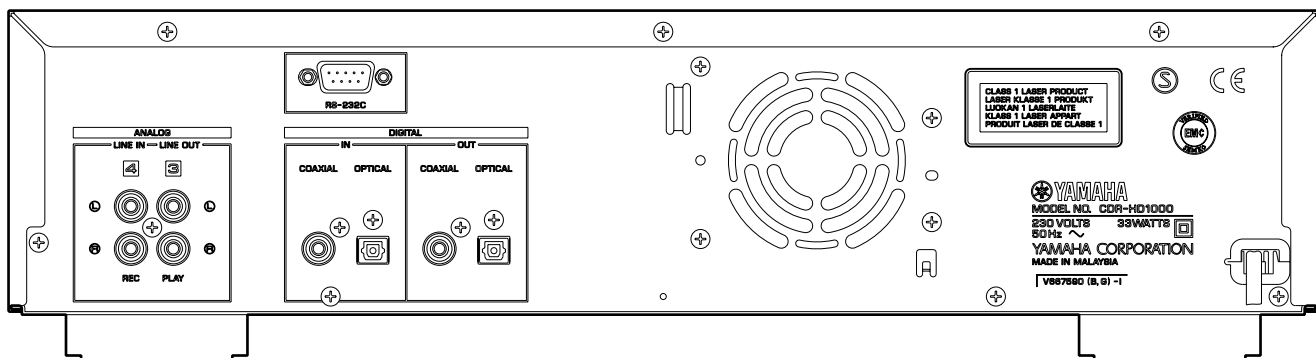

REMOTE CONTROL TRANSMITTER PANEL

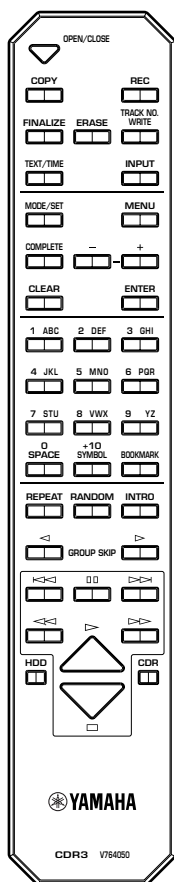

SPECIFICATIONS

GENERAL

Model	Compact disc and HDD recorder
Application disks	CDs, CD-Rs for AUDIO, CD-RWs for AUDIO
Power supply	
U, C models	AC 120 V 60 Hz
A model	AC 240 V 50 Hz
B, G models	AC 230 V 50 Hz
Power consumption	33 W
Standby power consumption	0 W
Operating temperature	+ 5 °C to + 35 °C
Max. dimensions (W x H x D)	
.....	435 x 115.5 x 414.5 mm (17-1/8" x 4-9/16" x 16-5/16")
	(include legs, terminals and knobs)
Weight	8.3 kg
Panel color	Black Color [U, C, A, G models]

AUDIO PERFORMANCE

Output level (1kHz 0dB)	2 ± 0.5 Vrms
Frequency characteristics (EIAJ)	
5Hz to 20kHz	± 0.5 dB
Playback signal to noise ratio (EIAJ)	105 dB or more
Playback dynamic range (EIAJ)	99 dB or more
Playback THD + noise (EIAJ)	0.004 % or less
Recording signal to noise ratio (EIAJ)	92 dB or more
Recording dynamic range (EIAJ)	93 dB or more
Recording THD + noise (EIAJ)	0.006 % or less

INPUT/OUTPUT

LINE OUTPUT

Output level	2 Vrms
Output resistance	990 ohms

LINE INPUT

Input sensitivity	500 mVrms
Input impedance	24 k-ohms (REC LEVEL Max.)

DIGITAL OUTPUT

Coaxial output level	0.5 Vp-p (75 ohms)
Optical output level	-20 dBm
Sampling frequency	44.1 kHz

DIGITAL INPUT

Coaxial input level	0.5 Vp-p (75 ohms)
Optical input level	-20 dBm
Input gain (with Digital Volume)	±12 dB
Input gain (without Digital Volume)	±0 dB
Sampling frequency tolerance	32 kHz, 44.1 kHz, 48 kHz and 96 kHz

HEADPHONE OUTPUT (PHONES LEVEL MAX)

Output level (-20 dB, 150 ohms load)	300 mVrms
--	-----------

* Specifications are subject to change without notice due to product improvements.

U U.S.A. model

C Canadian model

A Australian model

G European model

DIMENSIONS

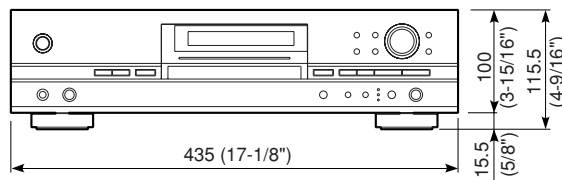
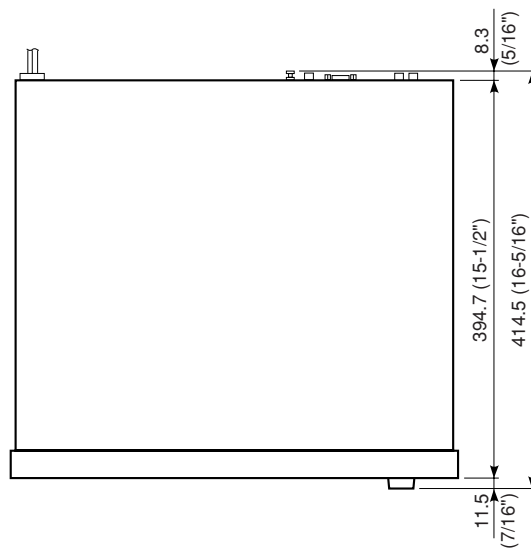

Unit : mm (inch)

INTERNAL VIEW

- ① OPERATION (6) P.C.B.
- ② OPERATION (7) P.C.B.
- ③ OPERATION (8) P.C.B.
- ④ MAIN P.C.B.
- ⑤ OPERATION (1) P.C.B.
- ⑥ HDD UNIT
- ⑦ OPERATION (2) P.C.B.
- ⑧ CDR UNIT
- ⑨ OPERATION (3) P.C.B.
- ⑩ OPERATION (5) P.C.B.
- ⑪ OPERATION (4) P.C.B.

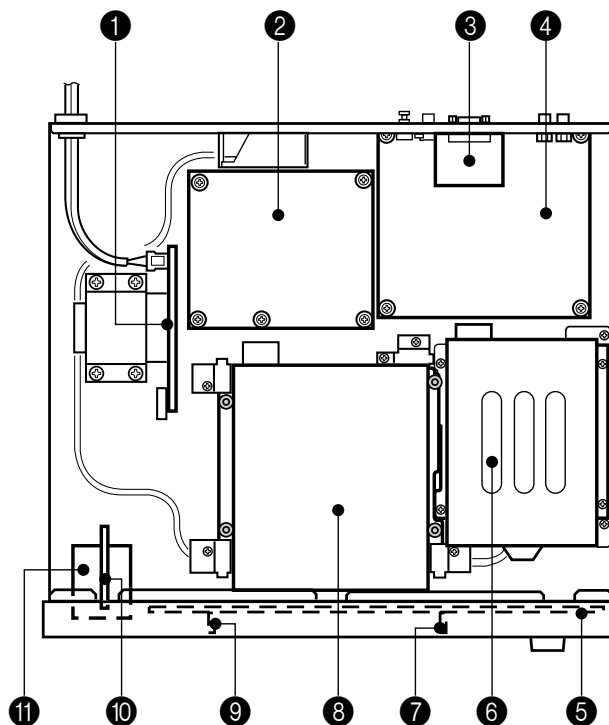

DISASSEMBLY PROCEDURES

(Remove parts in the order as numbered.)

CDR Mechanical Unit replacement

- The CDR mechanical unit must be replaced as a unit. None of its components can be supplied separately.
- When replacing the CDR mechanical unit, write down the following items.
 - Serial No. of the product and the symptom in detail
 - Mechanical serial No./mechanical shipping serial No. of the CDR mechanical unit
- When sending back the defective CDR mechanical unit for repair, send the whole unit.
- When sending back the defective CDR mechanical unit for repair, attach the disc that was used when the error occurred, if requested. However, Yamaha shall not be liable even if the data in the disc has become unreadable while the unit is being serviced/repaired.
- When replacing the CDR mechanical unit, be sure to order a laser precaution label, a radiation sheet, a sheet (U, C) and a damper (U, C) as spare parts and attach them to the new CDR mechanical unit. (Refer to the figure 4 in P6.)

1. Removal of Top Cover

- a. Turn off the power and disconnect the power plug from the AC power outlet.
- b. Remove 4 screws (①) and 3 screws (②). (Fig. 1)
- c. Remove the top cover rearward while lifting it up. (Fig. 1)

2. Removal of Front Panel Unit

- a. Disconnect 3 connectors (CB3, CB203, CB204) from the MAIN P.C.B.. (Fig. 1)
- b. Remove 3 screws (③) and 4 screws (④), and the Front Panel Unit can be removed forward. (Fig. 1)

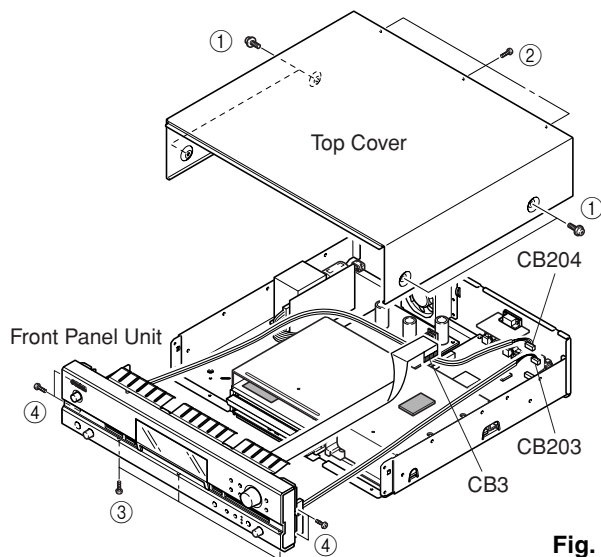

Fig. 1

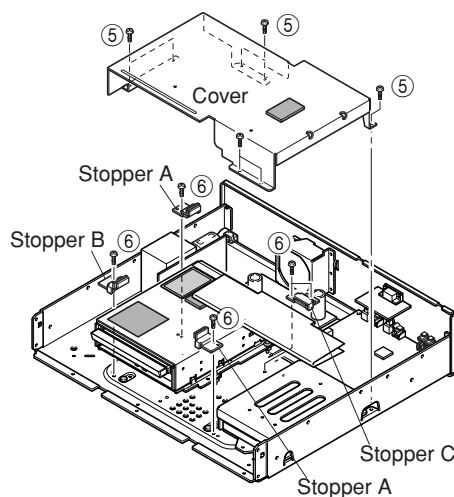

Fig. 2

3. Removal of CDR Unit

- Remove 7 screws (⑤) and then remove cover. (U, C models only) (Fig. 2).
- Disconnect the power cable, IDE cable and word clock cable from the CDR unit. (Fig. 3)
- Remove 5 screws (⑥) and then remove each stopper. (Fig. 2).
- Remove the CDR unit rearward while lifting it up. (Fig. 2)

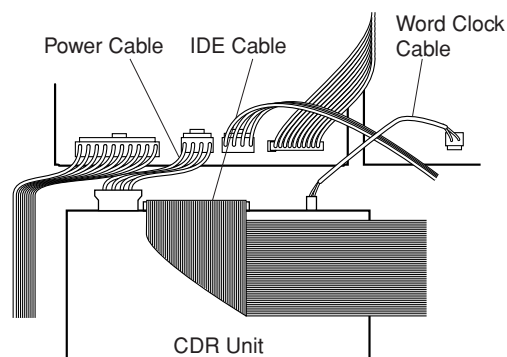

Fig. 3

4. Disassembly of CDR Unit

- Remove 4 screws (⑦) and (⑧) respectively and then remove the lower frame. (Fig. 4)
- To open the tray, move the manual eject lever located on the bottom face. (Fig. 5)
- Remove the lid upward. (Fig. 4)

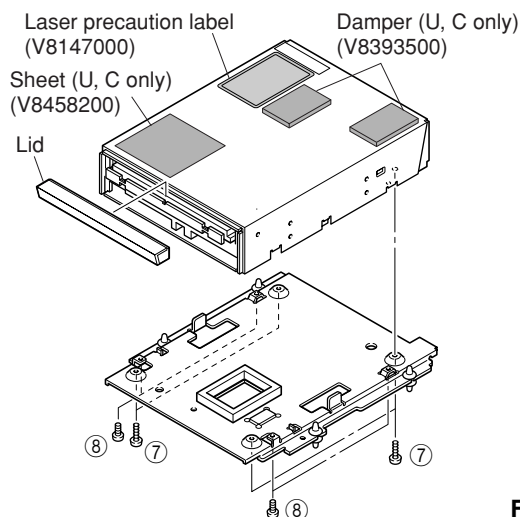

Fig. 4

5. Assembly of CDR Mechanical Unit

- Insert the jumper pin of the new CDR mechanical unit at the slave position. (Fig. 6)
- Attach the laser precaution label on the upper frame of the new CDR mechanical unit. (Fig. 4)

U, C models only

- Attach the sheet and the damper on the upper frame of the new CDR mechanical unit. (Fig. 4)
- Attach the radiation sheet to the IC2 located on the bottom face of the new CDR mechanical unit. (Fig. 5)
- Install the lower frame and fix it with 4 screws (⑦) and (⑧) respectively. (Fig. 4)

6. Installation of CDR Unit

- Connect the power cable, IDE cable and word clock cable to the CDR unit. (Fig. 3)
- Install the CDR unit by inserting it from the rear. (Fig. 2)
- Using 5 screws (⑥), install each stopper. (Fig. 2)
- Install the cover and fix it with 7 screws (⑤). (Fig. 2)

7. Installation of Front Panel Unit

- Connect 3 connectors (CB3, CB203, CB204) to the MAIN P.C.B.. (Fig. 1)
- Install the Front Panel Unit and fix it with 3 screws (③) and 4 screws (④). (Fig. 1)

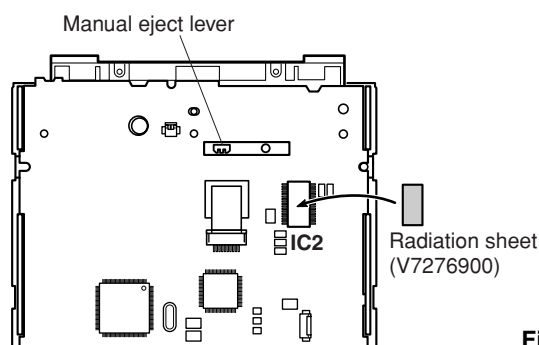

Fig. 5

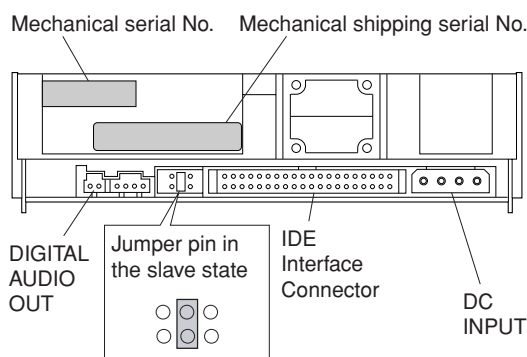

Fig. 6

HDD replacement

- The HDD must be replaced as a unit. None of its components can be supplied separately.
- When replacing the HDD, write down the following items.
 - Serial No. of the product and the symptom in detail
 - Mechanical serial No./mechanical shipping serial No. of the HDD
- After replacing the hard disc, be sure to initialize it using the "HDD format" procedure on page 13.

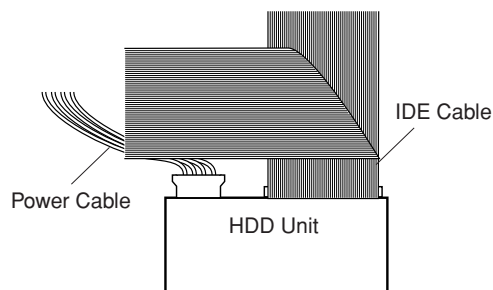

Fig. 7

1. Removal of HDD Unit

- Disconnect the power cable and IDE cable from the HDD unit. (Fig. 7)
- Remove 4 screws (9) and then remove the holder. (Fig. 8)
- Take out the HDD unit. (Fig. 8)

2. Disassembly of HDD Unit

- Take out the HDD unit from the case. (Fig. 8)
- Remove 4 screws (10) and then remove the plate. (Fig. 8)
- Remove 4 screws (11) and then remove the mounter. (Fig. 8)

3. Assembly of HDD

- Insert the jumper pin of the new HDD unit at the master position.
- Install the mounter with 4 screws (11). (Fig. 8)
- Install the plate with 4 screws (10). (Fig. 8)
- Enclose the HDD unit with the case. (Fig. 8)

4. Installation of HDD Unit

- Connect the power cable and IDE cable to the HDD unit. (Fig. 7)
- Put the HDD unit in place. (Fig. 8)
- Using 4 screws (9), install the holder. (Fig. 8)

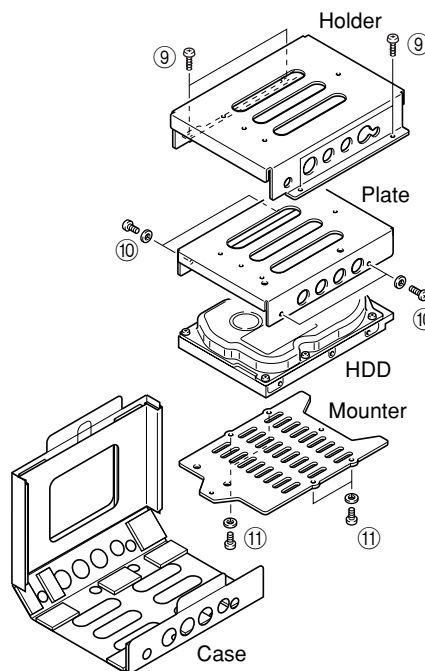
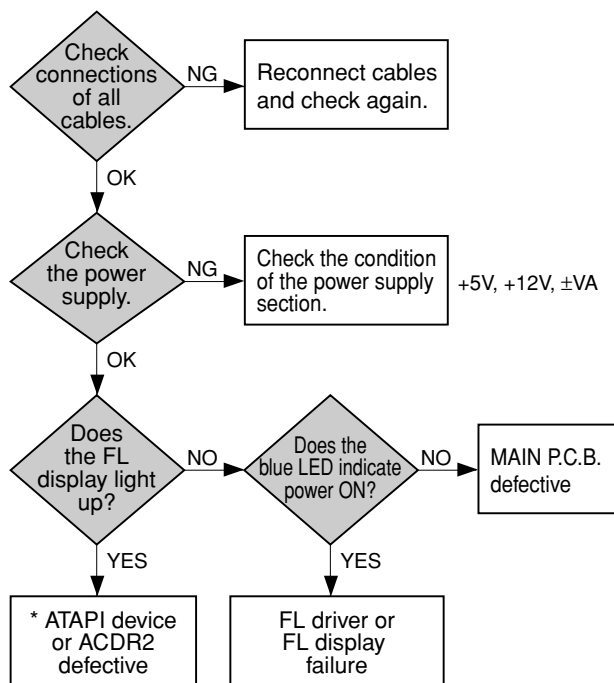

Fig. 8

■ SERVICE CHECK PROCEDURES

When the main unit fails to operate



* ATAPI device means HDD and CD-R/W drive.

When MAIN P.C.B. is defective

The MAIN P.C.B. consists of the following 3 blocks.

- 1) CPU, RAM and flash ROM
- 2) ACDR2 and DIR5
- 3) CODEC and analog

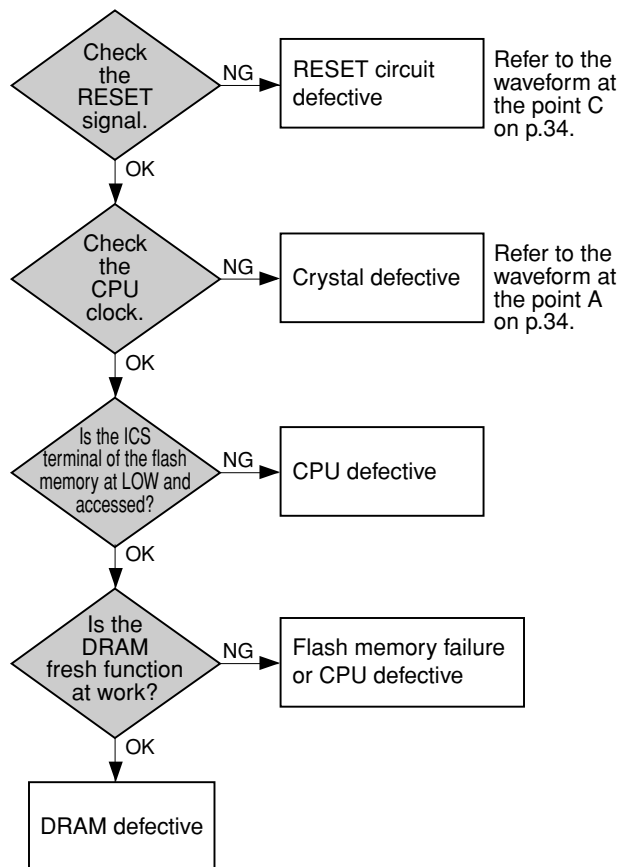

When ATAPI device is defective

Possible symptom varies depending on the defective point.

- "HDD CHECK" appears on the FL display.
- Only the scale of the level meter appears on the FL display.
- Turning on the drive switch will result in hang-up.
- Abnormal mechanical noise is heard from the unit.

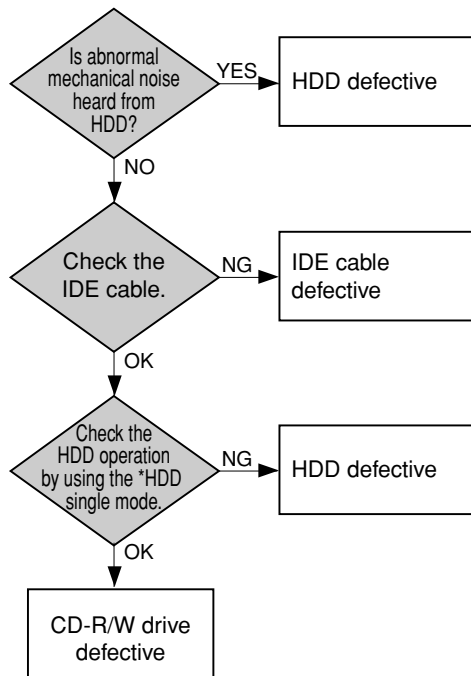

* For the HDD single mode, refer to the description of the HDD single mode.

HDD single mode

By using the HDD single mode, it is possible to operate the HDD alone.

Starting the HDD single mode

- 1) Turn off the power.
- 2) Disconnect the IDE cable connected to the CD-R/W drive. (Refer to the figure 3 in p.6.)
- 3) While pressing the MENU key and  key simultaneously, turn on the power and keep pressing these keys.
- 4) The program version is displayed first followed by the HDD.

Functions of the HDD single mode

None of the CDR key, the COPY key and the  key functions.

Other keys function just like in the normal mode.

HDD operation check

- 1) Record the music signals from the external equipment connected to the main unit on to the HDD.
- 2) Reproduce the music signals recorded on to the HDD.

Caution

As the audio circuit in this equipment uses a word clock (44.1kHz) of the CD-R/W, do not disconnect the word clock cable.

When the word clock cable is disconnected, this equipment will fail to operate properly. (Refer to the figure 3 in p.6.)

ACDR2 check

By using the mode 1 and mode 2 of the P.C.B. test mode, the operation of the ACDR2 can be checked.

In Mode 1, the analog signal input/output operation is checked. In Mode 1, it is possible to check the A/D and D/A converter function of CODEC, signal flow in ACDR2, operation of the low pass filter in the input/output circuit.

In mode 2, the input/output operation of the digital signal is checked.

The ACDR2 decodes the sub-code and displays the track No. and the track time. To test this decoding function, the digital output of the CD player is used.

If the operation in Mode 1 and Mode 2 is normal, the ACDR2 is judged as normal.

Starting the P.C.B test mode

- 1) Turn off the power.
- 2) Short between pins No.1 and No.2 of the CB5. (MAIN P.C.B., 3B in p.26)
- 3) Turn on the power.
- 4) The P.C.B test mode is activated and "TEST mode PCB" is displayed.

Mode 1 operation check

- 1) Set to Mode 1 by pressing the ◀◀/◀◀ key. "TEST mode 1" is displayed.
- 2) Enter the analog signal through ANALOG LINE IN.
- 3) Check the analog signal output at ANALOG LINE OUT.

Mode 2 operation check

- 1) Set to Mode 2 by pressing the ▶▶/▶▶ key. "TEST mode 2" is displayed, followed by "mode2 00 00 00".
- 2) Apply the digital coaxial output signal of the CD player into DIGITAL COAXIAL IN.
- 3) Check the output signal at DIGITAL OUT.
- 4) Check the output signal at ANALOG LINE OUT.
- 5) Check the track No. and track time on display.

Signal flow diagram of Mode 1

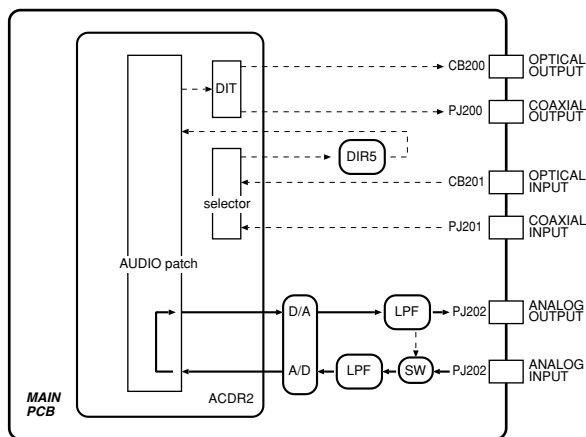

Signal flow diagram of Mode 2.

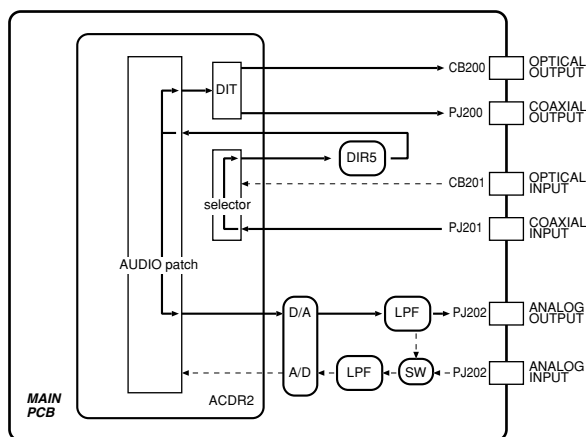

INSPECTIONS

Instruments Required for Inspection

- CD test disc (YEDS-18: TX911730)
- CD-RW disc (TDK CD-RW AUDIO 74min [XA74])
- CD player with digital output (optical/coaxial) function (used as a digital signal generator)
- AV amplifier with digital input (optical/coaxial) function (used as a D/A converter)
- Analog signal generator
- Oscilloscope
- Level meter
- Distortion meter

Step	Item	Mode	Input signal	Disc	Check method and standard
1	Display	Test mode		No disc	<ol style="list-style-type: none"> 1. Turn on the power while pressing the "◀◀/◀◀" key and the "▶▶/▶▶" key. Keep pressing the "◀◀/◀◀" key and the "▶▶/▶▶" key until "TEST mode" is displayed. 2. Check that all FL display units light up and go off properly by pressing the "COPY" key. 3. Check each key for proper response as follows. When any key other than POWER, HDD, CDR and COPY is pressed, the corresponding key name should be displayed. Also, JOG Forward should appear when the MULTI JOG knob is turned clockwise and JOG Rewind should appear when it is turned counterclockwise. Also, each of operation indicator LEDs of CDR and HDD lights in blue and orange alternately every time the MULTI JOG knob is turned.

Step	Item	Mode	Input signal	Disc	Check method and standard
2	D/A converter	Normal mode		YEDS-18	<ol style="list-style-type: none"> 1. Turn on the power. (In normal mode) 2. Load the CD test disc (YEDS-18: TX911730). 3. Play track 2 (1kHz, 0dB). 4. Check that the output level of LINE OUT (ANALOG) is 2 ± 0.5Vrms. 5. Check that the distortion factor (1kHz) is 0.01% or less. 6. Play tracks 3 (20Hz) and 6 (20kHz) and check that the frequency response is 0 ± 1.5dB. 7. Play track 7 and check that S/N is 100dB or more.

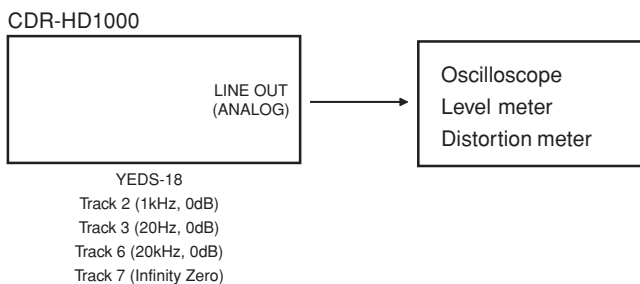

Step	Item	Mode	Input signal	Disc	Check method and standard
3	A/D converter	DAC mode	LINE IN (ANALOG) 1kHz, 20Hz, 20kHz 500mVrms	No disc	<ol style="list-style-type: none"> 1. Press the "MENU" key. Rotate the "MULTI JOG" knob to select "DAC mode" then press the "MULTI JOG" knob. 2. Set the INPUT selector to the ANALOG position. 3. Apply a 1kHz, 500mVrms analog signal to the LINE IN (ANALOG). 4. Demodulate the digital signal of DIGITAL OUT (COAXIAL) to analog. 5. Adjusting the ANALOG REC LEVEL control knob, check that the demodulated signal level can be set to 1Vrms. 6. At this time, check that the REC LEVEL control knob is close to the 12 o'clock position. 7. Check that the distortion factor is 0.02% or less. 8. Check that the S/N is 82dB or more. (Input shorted, REC LEVEL max.) 9. Check that the frequency response (at 20Hz and 20kHz) is 0 ± 1.5dB. 10. Press the "□" key to return to the normal mode.

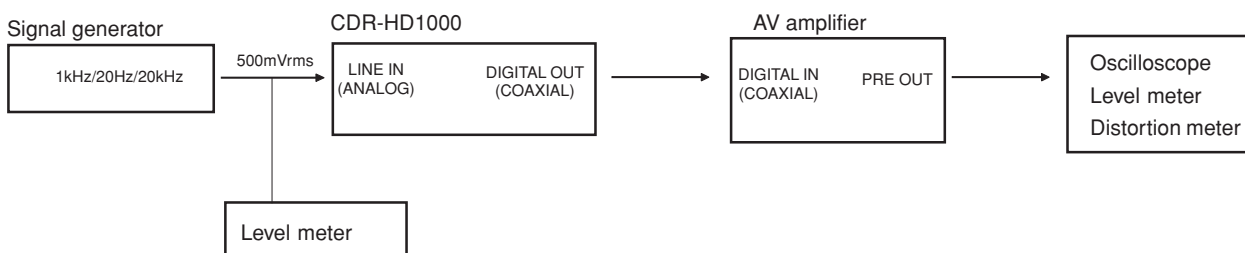

Step	Item	Mode	Input signal	Disc	Check method and standard
4	CD-RW recording	Normal mode		CD-RW	<ol style="list-style-type: none"> 1. Press the "CDR" key to select CD-R/W drive and then press the "\triangle" key to open the tray and set unfinalized CD-RW disc, and close the tray. 2. Press the REC key. <ul style="list-style-type: none"> • When it is judged as necessary to adjust the laser output for the disc being set, "OPC Adjust" is displayed and the laser output is automatically adjusted. (Adjustment takes approximately 15 seconds.) • When it is judged unnecessary to adjust the laser output for the disc being set, "Standby" is displayed. After a few seconds, "0 00" is displayed. 3. Press the "INPUT" key to select the external sound source. 4. Press the "$\triangleright / \square\square$" key to start recording. 5. Press the "\square" key to stop recording. Recommended recording time is over 20 seconds. 6. Wait for the track numbers to be displayed. Turn the "MULTI JOG" knob to select the last recorded track. 7. Press the "$\triangleright / \square\square$" key to play back the track and confirm it recorded correctly. 8. Press the "\triangle" key and remove the disc.

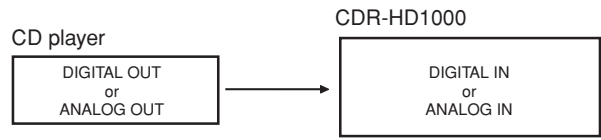

Step	Item	Mode	Input signal	Disc	Check method and standard
5	Copying CD \triangleright HDD	Normal mode		CD	<ol style="list-style-type: none"> 1. Insert a CD into the tray and close the tray. 2. Press the "COPY" key once to go to COPY Standby mode, blue LED at right side and amber LED at left side begin to blink slowly. 3. Press the "$\triangleright / \square\square$" key to start copying. 4. Press the "\square" key to stop copying. Recommended recording time is over 1 track time. 5. Press the "HDD" key to select HDD. 6. Press the "$\triangleright / \square\square$" key to play back the recorded track and confirm it recorded correctly. 7. Press the "\triangle" key, remove the disc and close the tray. 8. Check the disc and track numbers with recorded contents for testing. 9. Press the "HDD" key to select HDD. 10. Press the "MENU" key and turn the "MULTI JOG" knob to select "Disc Edit" and then press the "MULTI JOG" knob. 11. Turn the "MULTI JOG" knob to select "Disc Erase" and then press the "MULTI JOG" knob. 12. Select the disc No. with recorded contents for testing by turning the "MULTI JOG" knob and press it. 13. Press the "COMPLETE" key to erase the selected disc. 14. If there are more than one discs with recorded contents for testing, repeat Steps 11, 12 and 13. <p>* If it is allowed to format HDD, execute formatting instead of performing Steps 8 and after.</p>

■ FIRMWARE UPDATE PROCEDURES

1. Overview

CDR-HD1000 is capable of upgrading both of the system control firmware and the CD-R/W drive firmware by using the firmware CD-R.

The details of firmware CD-R availability will be provided by a Technical Bulletin.

2. Confirmation of the firmware versions

1. Press the "□" key.
2. Press the "MENU" key to enter MENU mode. "Album Edit" is displayed.
3. Rotate the "MULTI JOG" knob to select "Sys. Utility". Press the "MULTI JOG" knob.
4. "Firm. Version" appears is displayed. Press the "MULTI JOG" knob.
The system control firmware version is displayed with its compiled date and time.
The characters shown are scrolled once.
5. Rotate the "MULTI JOG" knob clockwise, the CD-R/W drive firmware version is displayed.
6. Rotate the "MULTI JOG" knob clockwise again, the HDD name is displayed.
7. Press the "MENU" key three times to return to the normal playback mode.

3. Upgrading of the firmware

3.1 Normal Update Operation

1. Press the "□" key.
2. Press the "CDR" key to select the CD-R/W drive.
3. Press the "△" key to open the disc tray. Load the "firmware CD-R" on the disc tray and press the "△" key to close the tray.
Wait to finish reading the disc.
4. Press the "MENU" key to enter MENU mode. "Album Edit" is displayed.
5. Rotate the "MULTI JOG" knob to select "Sys. Utility".
Press the "MULTI JOG" knob. "Firm. Version" is displayed.
6. Rotate the "MULTI JOG" knob to select "Firm. Update". Press the "MULTI JOG" knob.
7. "Main FW (CD)" is displayed. Three types of upgrade mode can be selected by rotating the "MULTI JOG" knob.
 - (1) "Main FW (CD)" means upgrading the system control firmware from CD-ROM.
 - (2) "CDRW FW (CD)" means upgrading the CD-R/W drive firmware from CD-ROM.
 - (3) "All FW (CD)" equal executing "Main FW (CD)" and "CDRW FW (CD)" at the same time.
8. Choose one mode and press the "MULTI JOG" knob.
9. "Push PLAY KEY" is displayed. Press the "▷/□□" key to start update.
10. "Downloading" is displayed. **NEVER TURN OFF THE POWER WHILE "Downloading" IS DISPLAYED.**
 - "Main FW (CD)" takes about 16 seconds.
 - "CDRW FW (CD)" takes about 32 seconds.
 - "All FW (CD)" takes about 48 seconds.
11. When finishing the upgrade, "Complete" is displayed and the CDR-HD1000 is rebooted.
12. Confirm that the firmware version has been changed from old to new.
13. If the firmware versions stay old, retry above updating procedures. And if the CDR-HD1000 does not work well after this updating, see section 3.2 to recover it.

3.2 Recovery mode

The updating procedure fails and the CDR-HD1000 malfunctions. In this case, the CDR-HD1000 has a recovery updating mode.

3.2.1 The system control firmware recovery

If "Firm. Update" is displayed when the CDR-HD1000 has finished the start up sequence, the system control firmware may be corrupted.

In this case, you can recover the system control firmware by the following procedures.

1. Press the "△" key to open the disc tray. Load the "firmware CD-R" on the disc tray and press the "△" key to close the tray.
Wait to finish reading the disc.
2. Rotate the "MULTI JOG" knob to select "Firm. Update". Press the "MULTI JOG" knob.
3. "Main FW (CD)" is displayed. Five types of upgrade mode can be selected by rotating the "MULTI JOG"

knob.

- (1) "Main FW (CD)" means upgrading the system control firmware from CD-ROM.
 - (2) "CDRW FW (CD)" means upgrading the CD-R/W drive firmware from CD-ROM.
 - (3) "All FW (CD)" equal executing "Main FW (CD)" and "CDRW FW (CD)" at the same time.
 - (4) "Main FW (HDD)" means upgrading the system control firmware from internal HDD backup.
 - (5) "CDRW FW (HDD)" means upgrading the CD-R/W drive firmware from internal HDD backup.
4. Select "Main FW (CD)" and press the "MULTI JOG" knob.
 5. "Push PLAY KEY" is displayed. Press the "▷/□□" key to start update.
 6. "Downloading" is displayed. **NEVER TURN OFF THE POWER WHILE "Downloading" IS DISPLAYED.**
 7. When finishing the recovery, "Complete" is displayed and the CDR-HD1000 is rebooted.
 8. Confirm that the firmware version has been changed from old to new.

3.2.2 The CD-R/W drive firmware recovery

If the CD-R/W drive doesn't work after updating its firmware, the CD-R/W drive firmware may be corrupted. In this case, you can recover the CD-R/W drive firmware by the following procedures.

1. Turn off the power.
Turn on the power while pressing the "□" key and the "MENU" key.
Keep pressing until the start up sequence is finished.
 2. Press the "MENU" key to enter MENU mode.
 3. Rotate the "MULTI JOG" knob to select "Sys. Utility".
Press the "MULTI JOG" knob. "Firm. Version" is displayed.
 4. Rotate the "MULTI JOG" knob to select "Firm. Update".
Press the "MULTI JOG" knob.
 5. "Main FW (HDD)" is displayed. Two types of upgrade mode can be selected by rotating the "MULTI JOG" knob.
 - (1) "Main FW (HDD)" means upgrading the system control firmware from internal HDD backup.
 - (2) "CDRW FW (HDD)" means upgrading the CD-R/W drive firmware from internal HDD backup.
 6. Select "CDRW FW (HDD)". Press the "MULTI JOG" knob.
 7. "Push PLAY KEY" is displayed. Press the "▷/□□" key to start update.
 8. "Downloading" is displayed. **NEVER TURN OFF THE POWER WHILE "Downloading" IS DISPLAYED.**
 9. When finishing the recovery, "Complete" is displayed and the CDR-HD1000 is rebooted.
 10. Confirm that the firmware version has been changed from old to new.
- CAUTION: Never press the "CDR" and "COPY" keys during the above sequence.

■ HDD FORMAT

Use the following procedure for initialization of the hard disk drive.

1. Turn on the power.
2. Press the "HDD" key to select HDD and then press the "MENU" key.
3. Turn the "MULTI JOG" knob to select "HDD Utility" and then press the "MULTI JOG" knob.
4. Turn the "MULTI JOG" knob to select "HDD Format" and then press the "MULTI JOG" knob. Then "Initialize ?" is displayed.
5. Press the "▷/□□" key, and "Format Really" is displayed.
6. Press the "INPUT" key.
7. Wait for "No data" to be displayed.
8. Turn off the power.

■ DISPLAY DATA

● V400 : BJ838GN (V7446200)

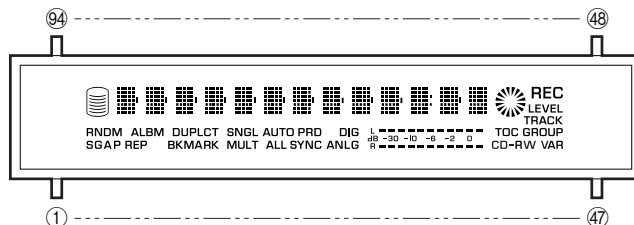

● PIN CONNECTION

Pin No.	94	93	92	91	90	89	88	87	86	85	84	83	82	81	80	79	78	77	76	75	74	73	72	71	70	69	68	67	66	65	64	63	62	61	60	59	58	57	56	55	54	53	52	51	50	49	48	
Connection	F1	F1	NP	NP	P27	P28	P29	P30	P31	P32	P33	P34	P35	P36	16G	15G	14G	13G	NX	NX	NX	NX	NX	NX	NX	NX	NX	NX	NX	NX	NX	12G	11G	10G	9G	8G	7G	6G	5G	4G	3G	2G	1G	IC	NP	NP	F2	F2

Pin No.	1	2	3	4	5	6	7	8	9	10	11	12	13	14	15	16	17	18	19	20	21	22	23	24	25	26	27	28	29	30	31	32	33	34	35	36	37	38	39	40	41	42	43	44	45	46	47
Connection	F1	F1	NP	NP	P26	P25	P24	P23	P22	P21	P20	P19	P18	P17	P16	P15	P14	NX	NX	NX	NX	NX	NX	NX	NX	NX	NX	NX	NX	P13	P12	P11	P10	P9	P8	P7	P6	P5	P4	P3	P2	P1	IC	NP	NP	F2	F2

Note : 1) F1, F2 Filament 2) NP No pin 3) NX No extend pin 4) DL Datum Line 5) 1G ~ 16G Grid 6) IC Internal connection

● GRID ASSIGNMENT

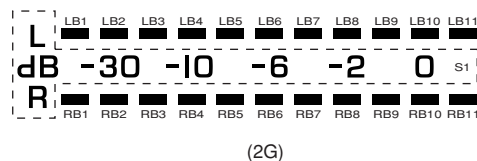
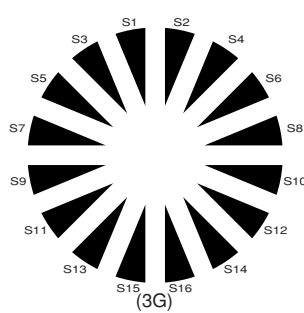
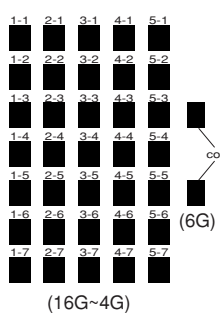
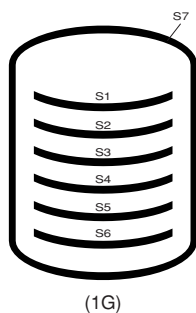
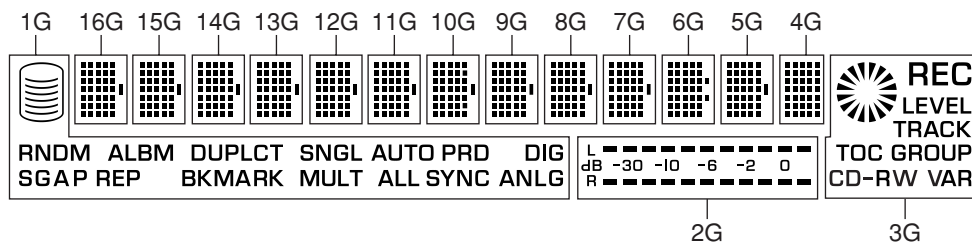

● ANODE CONNECTION

	1G	2G	3G	4G	5G	6G	7G~16G
P1	S7	RB1	S1	1-1	1-1	1-1	1-1
P2	S1	RB2	S2	2-1	2-1	2-1	2-1
P3	S2	RB2	S3	3-1	3-1	3-1	3-1
P4	S3	RB4	S4	4-1	4-1	4-1	4-1
P5	S4	RB5	S5	5-1	5-1	5-1	5-1
P6	S5	RB6	S6	1-2	1-2	1-2	1-2
P7	S6	RB7	S7	2-2	2-2	2-2	2-2
P8	—	RB8	S8	3-2	3-2	3-2	3-2
P9	—	RB9	S9	4-2	4-2	4-2	4-2
P10	—	RB10	S10	5-2	5-2	5-2	5-2
P11	—	RB11	S11	1-3	1-3	1-3	1-3
P12	—	S1	S12	2-3	2-3	2-3	2-3
P13	ANLG	LB1	S13	3-3	3-3	3-3	3-3
P14	DIG	LB2	S14	4-3	4-3	4-3	4-3
P15	SYNC	LB3	S15	5-3	5-3	5-3	5-3
P16	PRD	LB4	S16	1-4	1-4	1-4	1-4
P17	ALL	LB5	REC	2-4	2-4	2-4	2-4
P18	AUTO	LB6	LEVEL	3-4	3-4	3-4	3-4
P19	MULT	LB7	TRACK	4-4	4-4	4-4	4-4
P20	SNGL	LB8	TOC	5-4	5-4	5-4	5-4
P21	BKMARK	LB9	GROUP	1-5	1-5	1-5	1-5
P22	DUPLCT	LB10	CD	2-5	2-5	2-5	2-5
P23	REP	LB11	-R	3-5	3-5	3-5	3-5
P24	ALBM	—	W	4-5	4-5	4-5	4-5
P25	P	—	VAR	5-5	5-5	5-5	5-5
P26	A	—	—	1-6	1-6	1-6	1-6
P27	RNDM	—	—	2-6	2-6	2-6	2-6
P28	G	—	—	3-6	3-6	3-6	3-6
P29	S	—	—	4-6	4-6	4-6	4-6
P30	—	—	—	5-6	5-6	5-6	5-6
P31	—	—	—	1-7	1-7	1-7	1-7
P32	—	—	—	2-7	2-7	2-7	2-7
P33	—	—	—	3-7	3-7	3-7	3-7
P34	—	—	—	4-7	4-7	4-7	4-7
P35	—	—	—	5-7	5-7	5-7	5-7
P36	—	—	—	-	I	col	I

■ IC DATA

IC2 : HD6417014F28

μ-COM (CPU)

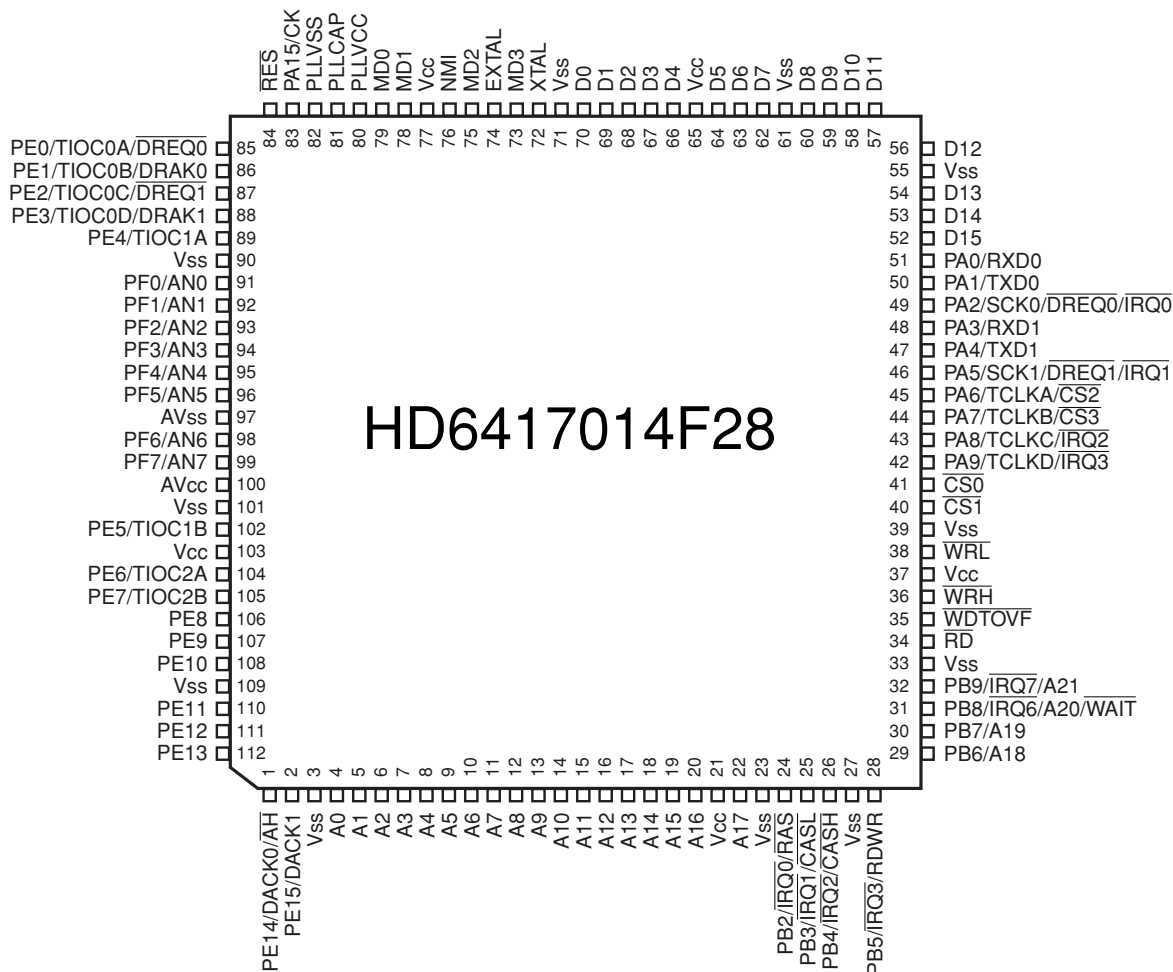

IC2 : HD6417014F28

Pin Description

No.	Port	Name	I/O	Function
1	DACK0	DACK0		for extend
2	PE15	LED3		for extend
3	VSS			GND
4	A0		O	Adress bus
5	A1		O	Adress bus
6	A2		O	Adress bus
7	A3		O	Adress bus
8	A4		O	Adress bus
9	A5		O	Adress bus
10	A6		O	Adress bus
11	A7		O	Adress bus
12	A8		O	Adress bus
13	A9		O	Adress bus
14	A10		O	Adress bus
15	A11		O	Adress bus
16	A12		O	Adress bus
17	A13		O	Adress bus
18	A14		O	Adress bus
19	A15		O	Adress bus
20	A16		O	Adress bus
21	Vcc			+5V power supply
22	A17		O	Adress bus
23	Vss			GND
24	/RAS	N_RAS	O	DRAM control
25	/CASL	N_CASL	O	DRAM control
26	/CASH	N_CASH	O	DRAM control
27	Vss			GND
28	RDWR	RDWR	O	DRAM control
29	A18		O	Adress bus
30	A19		O	Adress bus
31	/WAIT	N_WAIT	I	WAIT input
32	PB9	CPU_MUTE	O	Output mute
33	Vss			GND
34	/RD	N_RD	O	Read strobe
35	/WDTOVF			-
36	/WRH	N_WRH	O	Write strobe
37	Vcc			+5V power supply
38	/WRL	N_WRL	O	Write strobe
39	Vss			GND
40	/CS1	N_CDR	O	ACDR2 chip select
41	/CS0	N_ROM	O	Flash memory chip select
42	PA9	N_CPU_RST	O	Resetting peripheral devices
43	/IRQ2	N_IRQ2		for extend
44	/CS3	N_CS3		for extend
45	/CS2	N_CS2		for extend
46	/IRQ1	N_INT_CDR	I	ACDR2 interrupt
47	TXD1	TXD1	O	RS-232C output
48	RXD1	RXD1	I	RS-232C input
49	/IRQ0	N_INT_REM	I	Remote control input
50	TXD0	TXD0		for extend
51	RXD0	RXD0		for extend
52	D15		I/O	Data bus
53	D14		I/O	Data bus
54	D13		I/O	Data bus
55	Vss			GND
56	D12		I/O	Data bus

No.	Port	Name	I/O	Function
57	D11		I/O	Data Bus
58	D10		I/O	Data Bus
59	D9		I/O	Data Bus
60	D8			Data Bus
61	Vss			GND
62	D7		I/O	Data Bus
63	D6		I/O	Data Bus
64	D5		I/O	Data Bus
65	Vcc			+5V Power Supply
66	D4		I/O	Data Bus
67	D3		I/O	Data Bus
68	D2		I/O	Data Bus
69	D1		I/O	Data Bus
70	D0		I/O	Data Bus
71	Vss			GND
72	XTAL		O	Terminal for crystal oscillator
73	MD3		I	Setting CPU operation mode
74	EXTAL		I	Terminal for crystal oscillator
75	MD2		I	Setting CPU operation mode
76	NMI		I	NMI input
77	Vcc			+5V Power Supply
78	MD1		I	Setting CPU operation mode
79	MD0		I	Setting CPU operation mode
80	PLLVCC			+5V Power Supply
81	PLLCAP		O	PLL Capacitor Terminal
82	PLLVSS			GND
83	CK		O	Peripheral device clock
84	/RES		I	Reset input
85	TIOC0A	LED_HD_B	O	Panel LED control
86	TIOC0B	LED_HD_A	O	Panel LED control
87	TIOC0C	LED_CD_B	O	Panel LED control
88	TIOC0D	LED_CD_A	O	Panel LED control
89	PE4	SB_N_FL	O	FL control IC chip select
90	Vss			GND
91	AN0	PUI_KEY0	I	Panel key input
92	AN1	PUI_KEY1	I	Panel key input
93	AN2	PUI_KEY2	I	Panel key input
94	AN3	PUI_KEY3	I	Panel key input
95	AN4	PUI_KEY4	I	Panel key input
96	AN5	PUI_KEY5	I	Panel key input
97	AVSS			GND for A/D
98	AN6	PUI_KEY6	I	Panel key input
99	AN7	PUI_KEY7	I	for P.C.B. check
100	AVCC			+5V power supply for A/D
101	Vss			GND
102	PE5	SB_SCK	O	FL control IC serial clock
103	Vcc			+5V power supply
104	TIOC2A	CDR_FSCNT	I	–
105	PE7	FLASH_N_VPP		for extend
106	PE8	SB_DATA	O	FL control IC serial clock
107	PE9	DIP0		for extend
108	PE10	DIP1		for extend
109	VSS			GND
110	PE11	LED0		for extend
111	PE12	LED1		for extend
112	PE13	LED2		for extend

IC3 : YDC126-F
ACDR

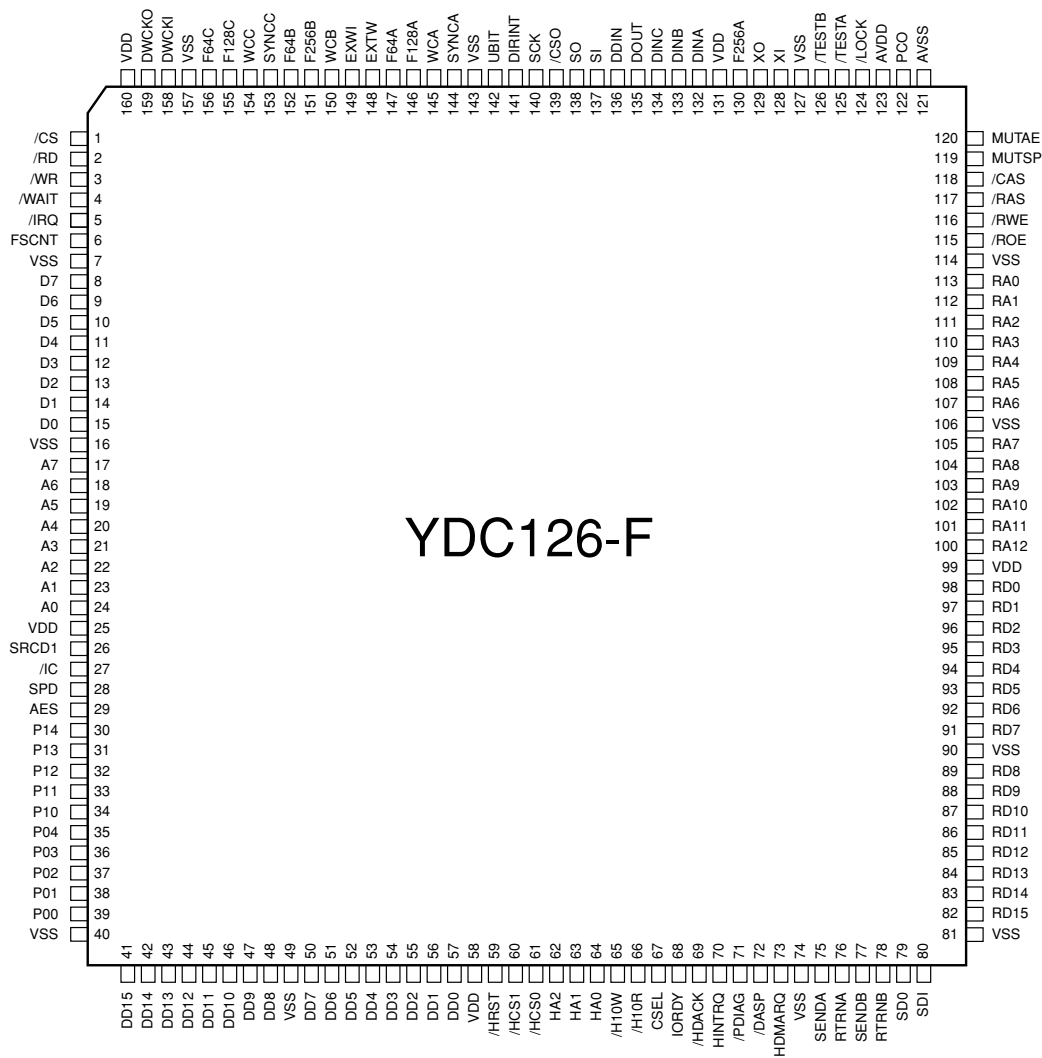

IC3 : YDC126-F

Pin Description

No.	Name	I/O	DC Level	Function
1	/CS	I	T	Microprocessor interface, chip select input
2	/RD	I	T	Microprocessor interface, read strobe input
3	/WR	I	T	Microprocessor interface, write strobe input
4	/WAIT	OD	C	Wait output
5	/IRQ	O	C	Interrupt request output
6	FSCNT	O\$	C	Dividing word clock output
7	VSS			GND
8	D7	I/O	T/C	Microprocessor interface, data bus
9	D6	I/O	T/C	Microprocessor interface, data bus
10	D5	I/O	T/C	Microprocessor interface, data bus
11	D4	I/O	T/C	Microprocessor interface, data bus
12	D3	I/O	T/C	Microprocessor interface, data bus
13	D2	I/O	T/C	Microprocessor interface, data bus
14	D1	I/O	T/C	Microprocessor interface, data bus
15	D0	I/O	T/C	Microprocessor interface, data bus
16	VSS			GND
17	A7	I	T	Microprocessor interface, data bus
18	A6	I	T	Microprocessor interface, data bus
19	A5	I	T	Microprocessor interface, data bus
20	A4	I	T	Microprocessor interface, data bus
21	A3	I	T	Microprocessor interface, data bus
22	A2	I	T	Microprocessor interface, data bus
23	A1	I	T	Microprocessor interface, data bus
24	A0	I	T	Microprocessor interface, data bus
25	VDD			Power supply +5V
26	SRCDI	I+	T	Unconnected
27	/IC	I	T	Initial clear input
28	SPD	O	C	Digital audio interface output (SPDIF)
29	AES	O	C	Unconnected
30	P14	I+	T	General purpose input port
31	P13	I+	T	General purpose input port
32	P12	I+	T	General purpose input port
33	P11	I+	T	General purpose input port
34	P10	I+	T	General purpose input port
35	P04	O	C	General purpose input port
36	P03	O	C	General purpose input port
37	P02	O	C	General purpose input port
38	P01	O	C	General purpose input port
39	P00	O	C	General purpose input port
40	VSS			GND
41	DD15	I/O	T/C	IDE bus interface, data bus
42	DD14	I/O	T/C	IDE bus interface, data bus
43	DD13	I/O	T/C	IDE bus interface, data bus
44	DD12	I/O	T/C	IDE bus interface, data bus
45	DD11	I/O	T/C	IDE bus interface, data bus
46	DD10	I/O	T/C	IDE bus interface, data bus
47	DD9	I/O	T/C	IDE bus interface, data bus
48	DD8	I/O	T/C	IDE bus interface, data bus
49	VSS			GND
50	DD7	I/O	T/C	IDE bus interface, data bus
51	DD6	I/O	T/C	IDE bus interface, data bus
52	DD5	I/O	T/C	IDE bus interface, data bus
53	DD4	I/O	T/C	IDE bus interface, data bus
54	DD3	I/O	T/C	IDE bus interface, data bus
55	DD2	I/O	T/C	IDE bus interface, data bus

No.	Name	I/O	DC Level	Function
56	DD1	I/O	T/C	IDE bus interface, data bus
57	DD0	I/O	T/C	IDE bus interface, data bus
58	VDD			Power supply +5V
59	/HRST	OT	C	IDE bus interface, reset output
60	/HCS1	OT	C	IDE bus interface, chip select output
61	/HCS0	OT	C	IDE bus interface, chip select output
62	HA2	OT	C	IDE bus interface, address output
63	HA1	OT	C	IDE bus interface, address output
64	HA0	OT	C	IDE bus interface, address output
65	/H10W	OT	C	IDE bus interface, write strobe output
66	/H10R	OT	C	IDE bus interface, read strobe output
67	CSEL	OT	C	IDE bus interface, cable select output
68	IORDY	I	T	IDE bus interface, channel ready input
69	/HDACK	OT	C	IDE bus interface, DMA acknowledge output
70	HINTRQ	I	T	IDE bus interface, interrupt request input
71	/PDIAG	OD	C	IDE bus interface, connection diagnosis output
72	/DASP	OD	C	IDE bus interface, active slave output
73	HDMARQ	I	T	IDE bus interface, DMA request input
74	VSS			GND
75	SEND A	O	C	DSP3 serial data interface output 1
76	RTRNA	I+	T	DSP3 serial data interface input 1
77	SEND B	O	C	DSP3 serial data interface output 2
78	RTRNB	I+	T	DSP3 serial data interface input 2
79	SDO	O	C	Serial audio data output
80	SDI	I	T	Serial audio data input
81	VSS			GND
82	RD15	I/O	T/C	External RAM interface, data bus
83	RD14	I/O	T/C	External RAM interface, data bus
84	RD13	I/O	T/C	External RAM interface, data bus
85	RD12	I/O	T/C	External RAM interface, data bus
86	RD11	I/O	T/C	External RAM interface, data bus
87	RD10	I/O	T/C	External RAM interface, data bus
88	RD9	I/O	T/C	External RAM interface, data bus
89	RD8	I/O	T/C	External RAM interface, data bus
90	VSS			GND
91	RD7	I/O	T/C	External RAM interface, data bus
92	RD6	I/O	T/C	External RAM interface, data bus
93	RD5	I/O	T/C	External RAM interface, data bus
94	RD4	I/O	T/C	External RAM interface, data bus
95	RD3	I/O	T/C	External RAM interface, data bus
96	RD2	I/O	T/C	External RAM interface, data bus
97	RD1	I/O	T/C	External RAM interface, data bus
98	RD0	I/O	T/C	External RAM interface, data bus
99	VDD			Power supply +5V
100	RA12	O	C	External RAM interface, address output
101	RA11	O	C	External RAM interface, address output
102	RA10	O	C	External RAM interface, address output
103	RA9	O	C	External RAM interface, address output
104	RA8	O	C	External RAM interface, address output
105	RA7	O	C	External RAM interface, address output
106	VSS			GND
107	RA6	O	C	External RAM interface, address output
108	RA5	O	C	External RAM interface, address output
109	RA4	O	C	External RAM interface, address output
110	RA3	O	C	External RAM interface, address output
111	RA2	O	C	External RAM interface, address output
112	RA1	O	C	External RAM interface, address output
113	RA0	O	C	External RAM interface, address output

No.	Name	I/O	DC Level	Function
114	VSS			GND
115	/ROE	O	C	External RAM interface, read strobe output
116	/RWE	O	C	External RAM interface, write strobe output
117	/RAS	O	C	External RAM interface, lower address strobe output
118	/CAS	O	C	External RAM interface column address strobe output
119	MUTSP	I	T	SPD pin mute control input, muting provided at "1"
120	MUTAE	I+	T	Unconnected
121	AVSS			Analog GND for PLL
122	PCO	A		Capacitance connection terminal for PLL
123	AVDD			Analog power supply for PLL +5V
124	/LOCK	O	C	Master clock, PLL lock detect output
125	/TESTA	I+	T	Unconnected (testing terminal)
126	/TESTB	I+	T	Unconnected (testing terminal)
127	VSS			GND
128	XI	I\$	C	24.576MHz crystal oscillator connection terminal (input)
129	XO	O\$	C	24.576MHz crystal oscillator connection terminal (output)
130	F256A	O\$	C	Master clock, dividing clock output (256fs)
131	VDD			Power supply +5V
132	DINA	I+	T	Digital audio interface input A
133	DINB	I+	T	Digital audio interface input B
134	DINC	I+	T	Digital audio interface input C
135	DOUT	O	C	Digital audio interface output
136	DDIN	I	T	Serial audio data input
137	SI	I+	T	DIR5 interface, control data input
138	SO	O	C	DIR5 interface, control data output
139	/CSO	O	C	DIR5 interface, chip select output
140	SCK	O\$	C	DIR5 interface, bit clock output
141	DIRINT	I+	T	DIR5 interface, interrupt input
142	UBIT	I+	T	DIR5 interface, U-bit signal input
143	VSS			GND
144	SYNCA	O	C	Master clock system, synchronous signal output
145	WCA	O\$	C	Master clock system, word clock output (fs)
146	F128A	O\$	C	Master clock system, dividing clock output (128fs)
147	F64A	O\$	C	Master clock system, dividing clock output (64fs)
148	EXTW	O\$	C	Word clock output (fs)
149	EXWI	I\$+	T	External word clock input (fs)
150	WCB	I\$	T	Digital input data system, word clock input (fs)
151	F256B	I\$	T	Digital input data system, dividing clock input (256fs)
152	F64B	I\$	T	Digital input data system, dividing clock input (64fs)
153	SYNCC	I+	T	Unconnected
154	WCC	I\$+	T	Mode switching, "1": normal operation, "0": PLL constant output mode
155	F128C	I\$+	T	Unconnected
156	F64C	I\$+	T	Unconnected
157	VSS			GND
158	DWCKI	I\$	T	Drive word clock input (44.1kHz or 33.8688MHz)
159	DWCKO	O\$	C	Drive word clock output (for charge couple)
160	VDD			Power supply +5V

I/O I: Input O: Output I/O: Bi-directional \$: Clock signal OT: Tri-state output
 +: Pull-up resistor built-in A: Analog terminal OD: Open drain

DC C: CMOS level T: TTL level

IC401 : M66004MAFP-200C
FL tube driver

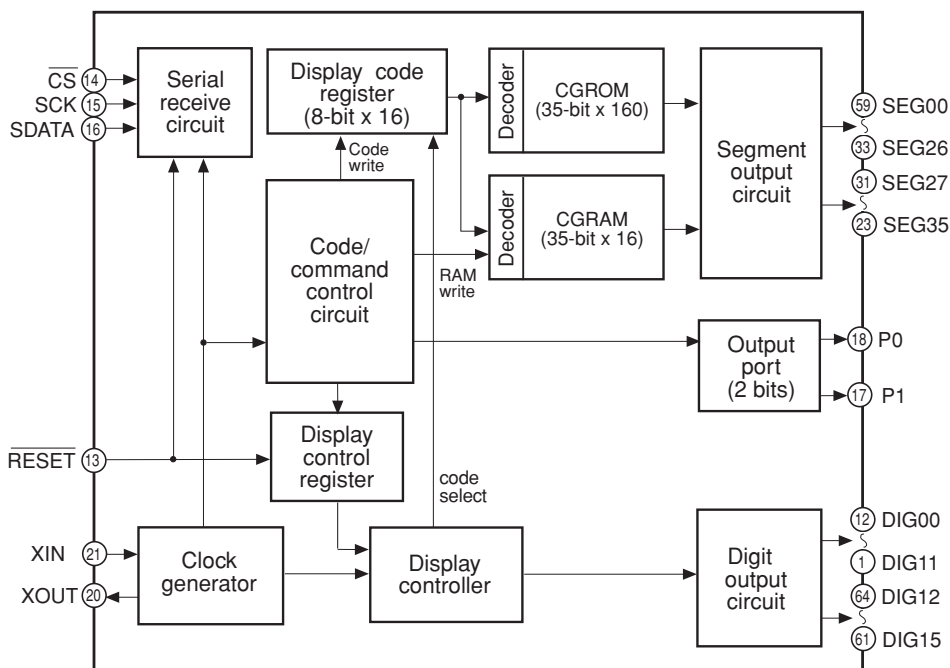
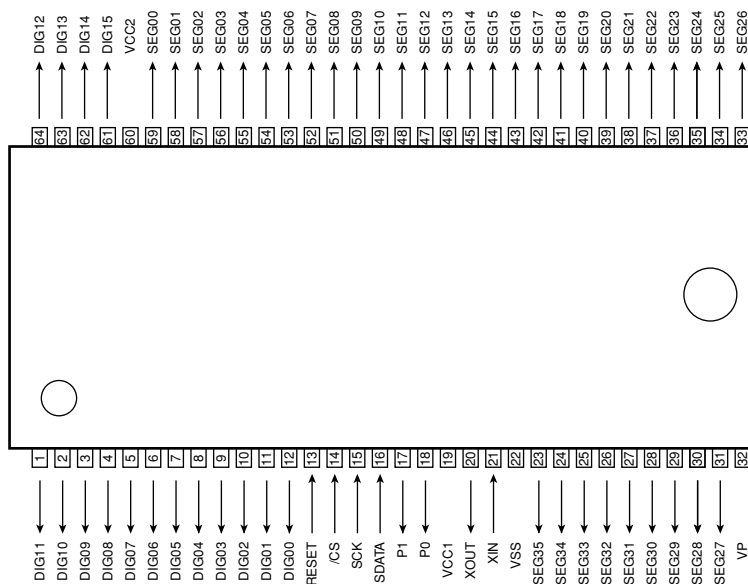

IC401 : M66004MAFP-200C
Pin Description

No.	Name	IN/OUT	Function
1	DIG11	O	Digit output
2	DIG10	O	Digit output
3	DIG09	O	Digit output
4	DIG08	O	Digit output
5	DIG07	O	Digit output
6	DIG06	O	Digit output
7	DIG05	O	Digit output
8	DIG04	O	Digit output
9	DIG03	O	Digit output
10	DIG02	O	Digit output

No.	Name	IN/OUT	Function
11	DIG01	O	Digit output
12	DIG00	O	Digit output
13	/RESET	I	Reset input
14	/CS	I	Chip select input
15	SCK	I	Shift clock input
16	SDATA	I	Serial data input
17	P1	O	Output port (static operation)
18	P0	O	Output port (static operation)
19	VCC1		Positive power supply for internal logic
20	XOUT	O	Clock output
21	XIN	I	Clock input
22	VSS		GND
23	SEG35	O	Segment output
24	SEG34	O	Segment output
25	SEG33	O	Segment output
26	SEG32	O	Segment output
27	SEG31	O	Segment output
28	SEG30	O	Segment output
29	SEG29	O	Segment output
30	SEG28	O	Segment output
31	SEG27	O	Segment output
32	VP		Negative power supply for VFD drive
33	SEG26	O	Segment output
34	SEG25	O	Segment output
35	SEG24	O	Segment output
36	SEG23	O	Segment output
37	SEG22	O	Segment output
38	SEG21	O	Segment output
39	SEG20	O	Segment output
40	SEG19	O	Segment output
41	SEG18	O	Segment output
42	SEG17	O	Segment output
43	SEG16	O	Segment output
44	SEG15	O	Segment output
45	SEG14	O	Segment output
46	SEG13	O	Segment output
47	SEG12	O	Segment output
48	SEG11	O	Segment output
49	SEG10	O	Segment output
50	SEG09	O	Segment output
51	SEG08	O	Segment output
52	SEG07	O	Segment output
53	SEG06	O	Segment output
54	SEG05	O	Segment output
55	SEG04	O	Segment output
56	SEG03	O	Segment output
57	SEG02	O	Segment output
58	SEG01	O	Segment output
59	SEG00	O	Segment output
60	VCC2		Positive power supply for high-pressure-resistant output port
61	DIG15	O	Digit output
62	DIG14	O	Digit output
63	DIG13	O	Digit output
64	DIG12	O	Digit output

■ BLOCK DIAGRAM

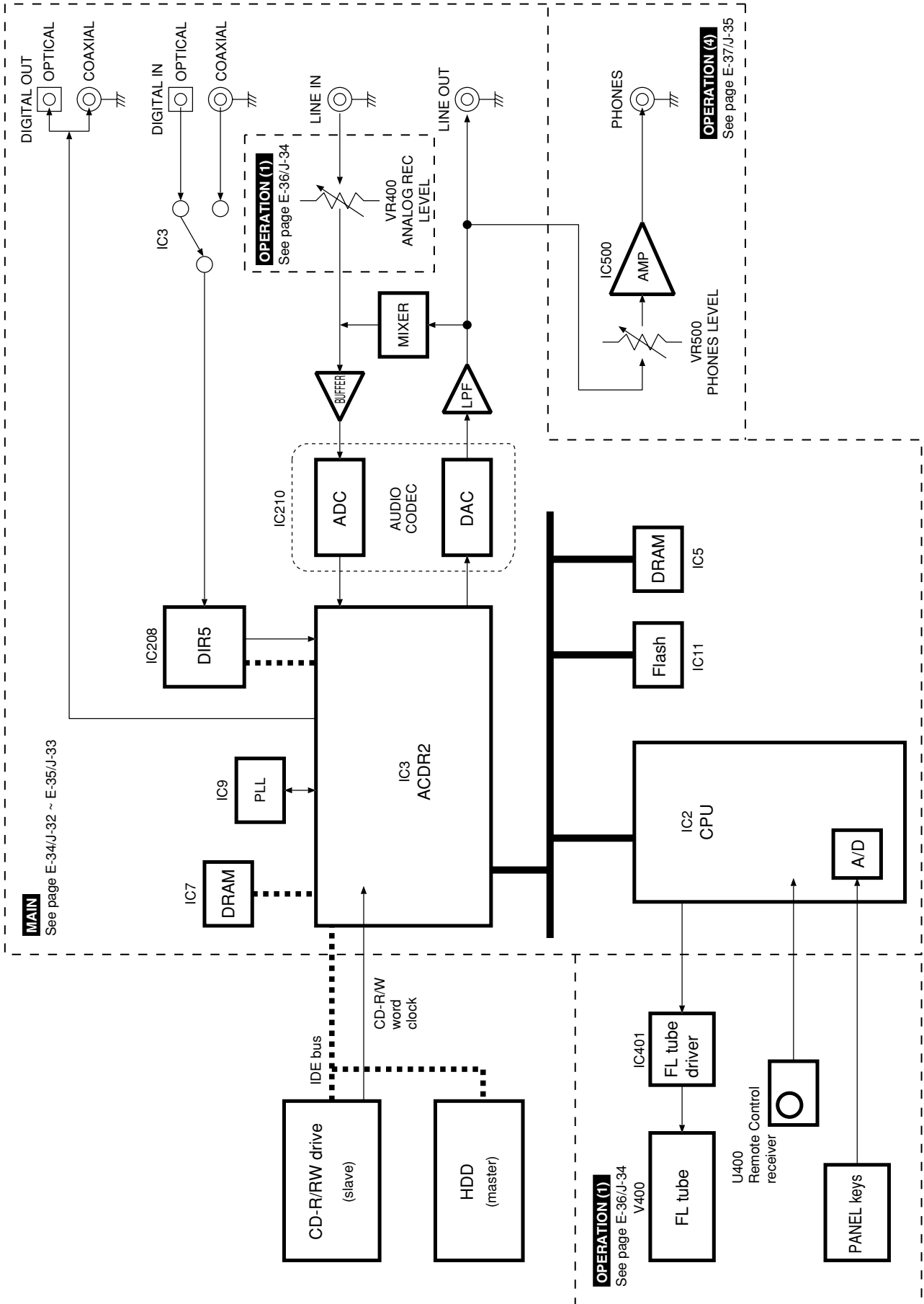

1 ■ PRINTED CIRCUIT BOARD (Foil side)

MAIN P. C. B.
(Lead Type Device)

From OPERATION (1)

- LED HD A
- LED HD B
- LED CD A
- LED CD B
- GND
- KEY0
- KEY1
- KEY2
- KEY3
- KEY4
- KEY5
- KEY6
- POUTO
- REM
- +5V
- VREF
- FL N CS
- FL SCK
- FL DATA
- FL N_RST
- FLGND
- FL1
- FL2
- GND

- PMUTE
- FL2
- FL1
- VP
- VA
- AGND
- +VA
- GND
- +5V

From OPERATION (7)

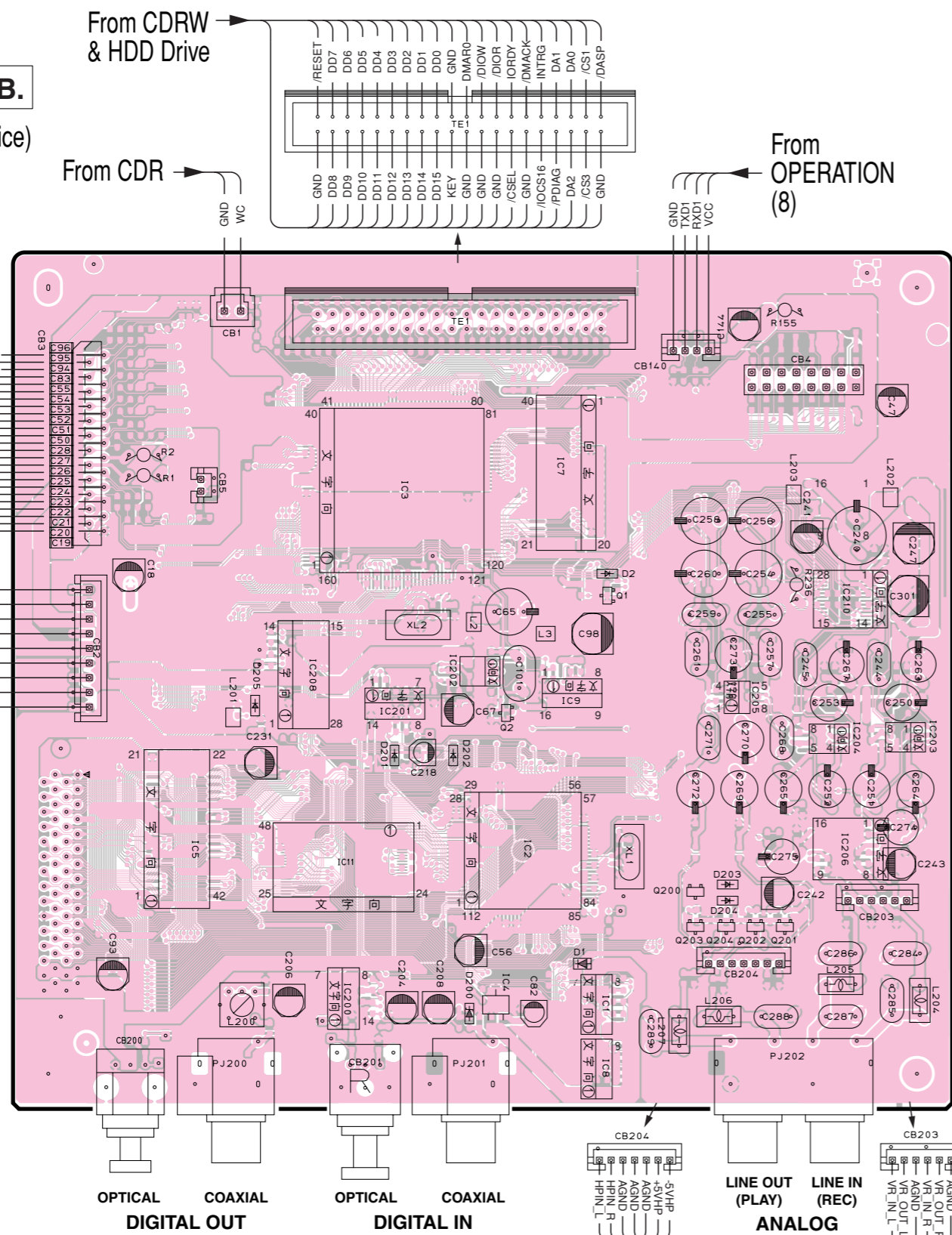

MAIN P. C. B.
(Surface Mount Device)

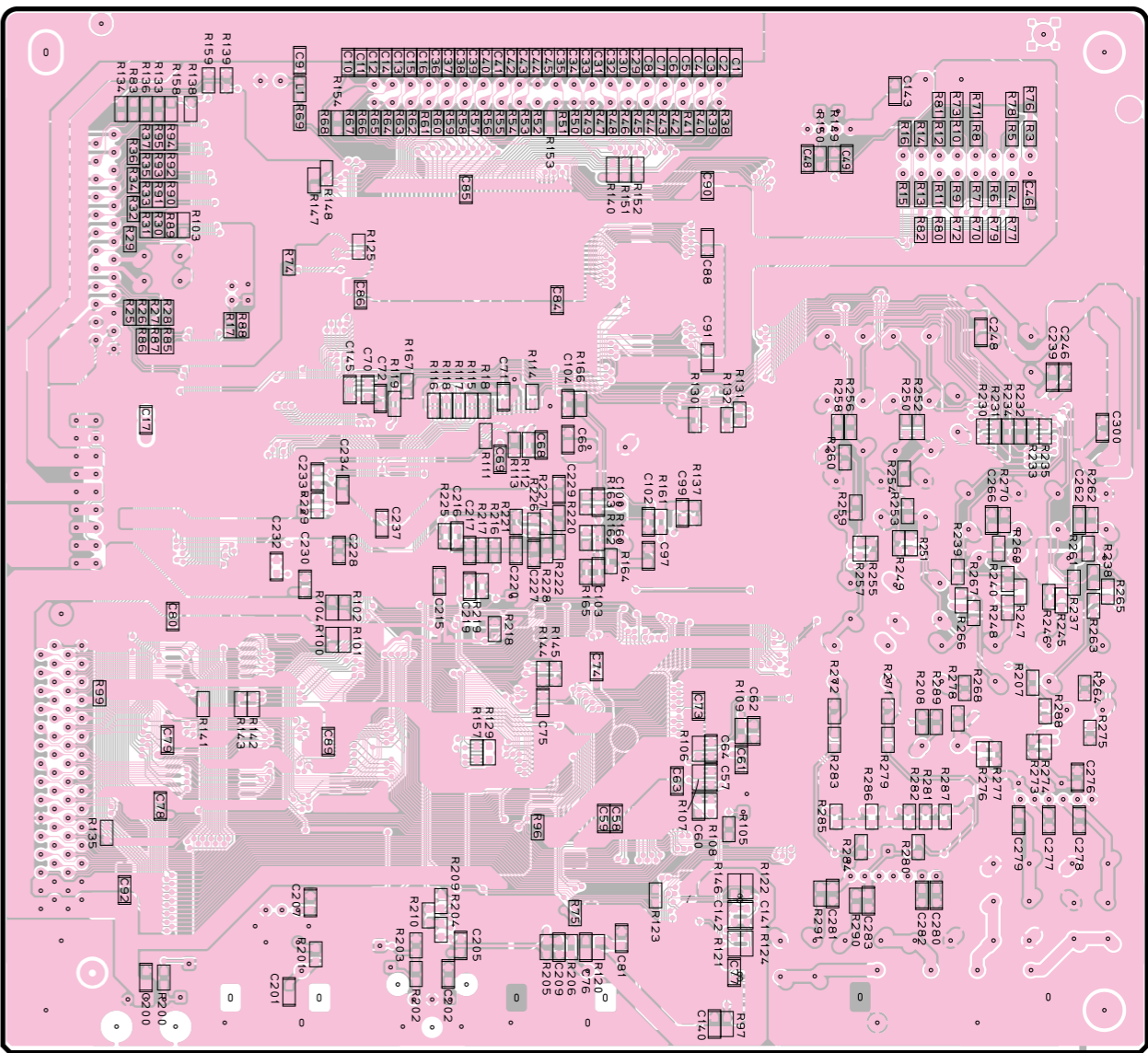

• Semiconductor Location

Ref. No.	Location	Ref. No.	Location	Ref. No.	Location
D1	D6	IC4	D6	IC205	E4
D2	D4	IC5	B5	IC206	E5
D200	D6	IC7	D3	IC208	C4
D201	C5	IC8	D6	IC210	E4
D202	D5	IC9	D4	Q1	D4
D203	E5	IC11	C5	Q2	D4
D204	E5	IC200	C6	Q200	E5
D205	C4	IC201	C4	Q201	E5
IC1	D6	IC202	D4	Q202	E5
IC2	D5	IC203	E5	Q203	E5
IC3	C3	IC204	E5	Q204	E5

PRINTED CIRCUIT BOARD (Foil side)

OPERATION (1) P. C. B. (Lead Type Device)

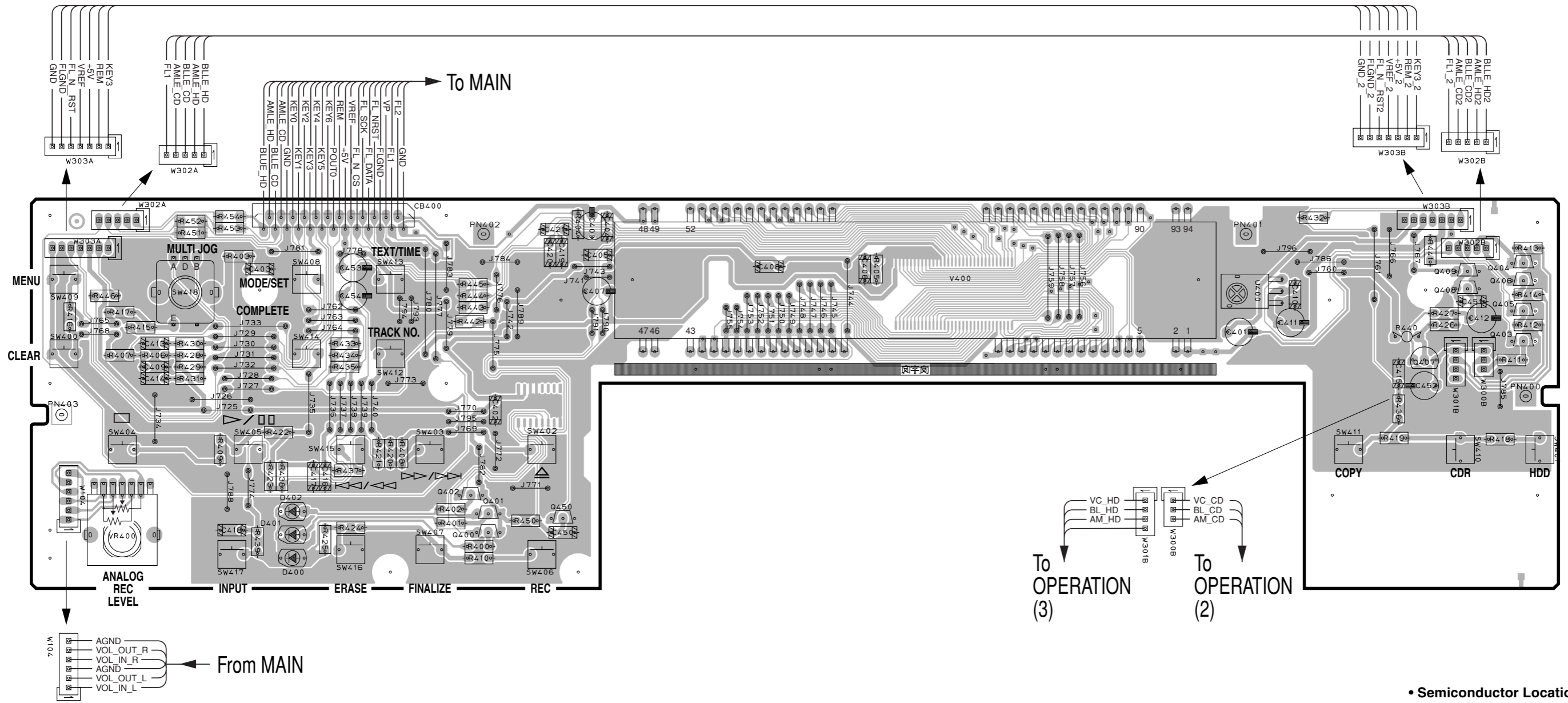

• Semiconductor Location

Ref. No.	Location
D400	B5
D401	B5
D402	B5
Q400	D5
Q401	D5
Q402	C5
Q403	J4
Q404	J3
Q405	J3
Q406	J3
Q407	I4
Q408	I3
Q409	I3
Q450	D5

SCHEMATIC DIAGRAM (MAIN 1/2)

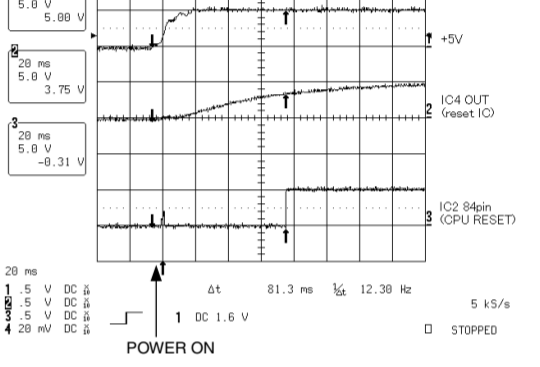
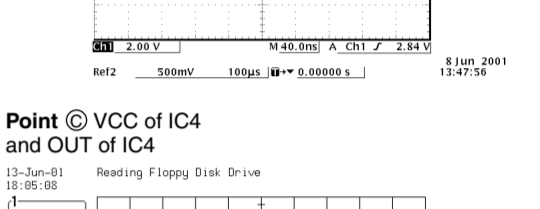
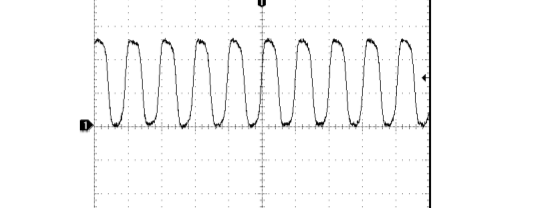
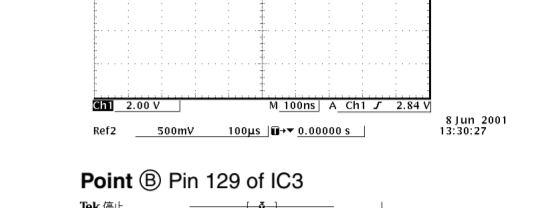
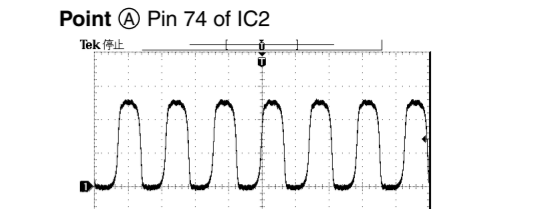
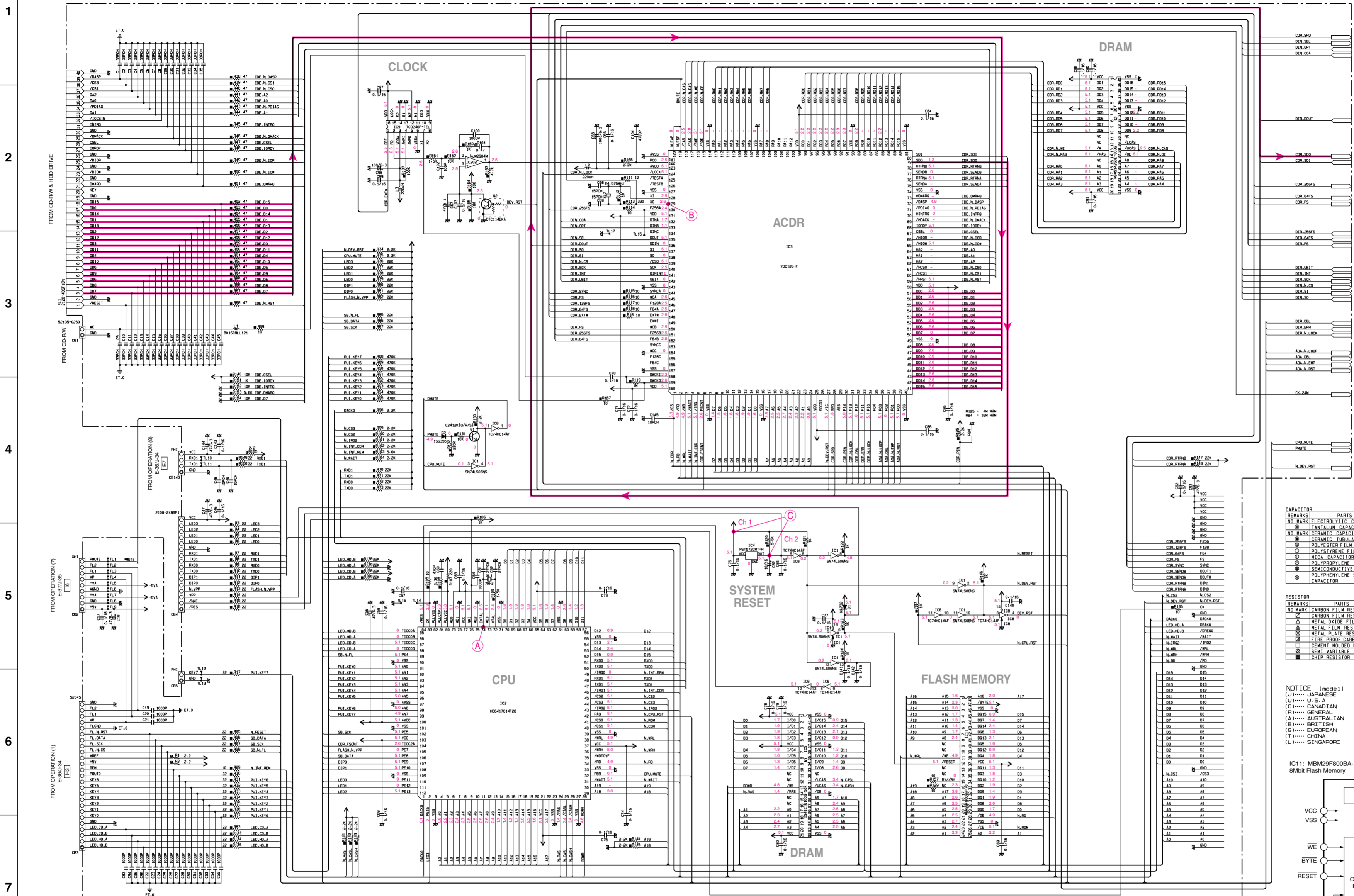
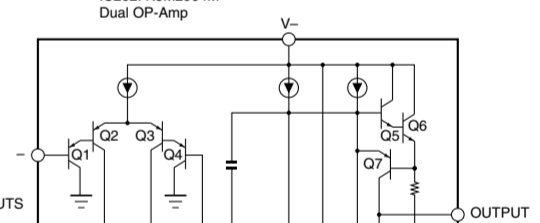
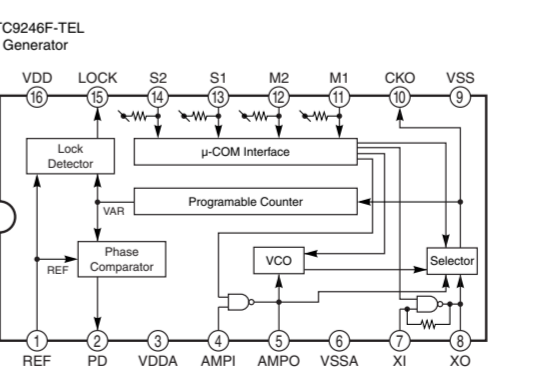
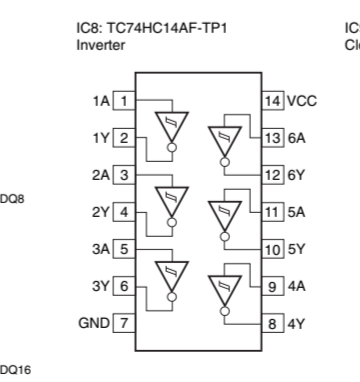
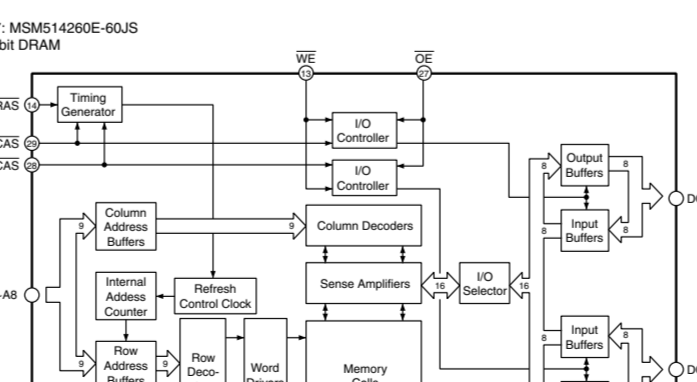
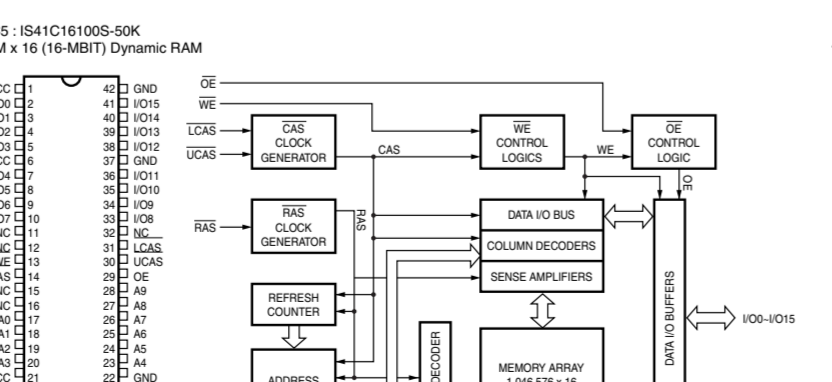
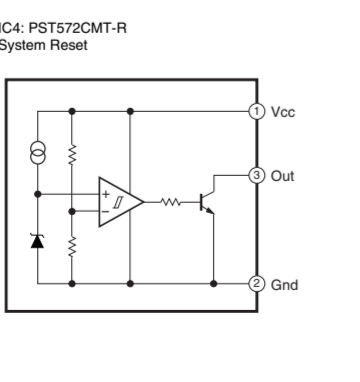
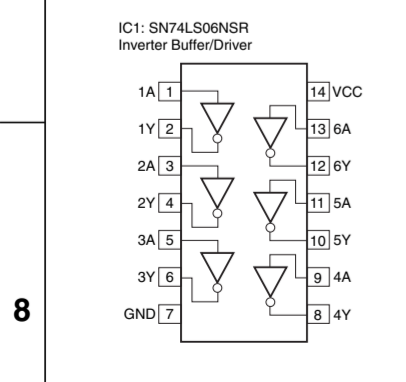
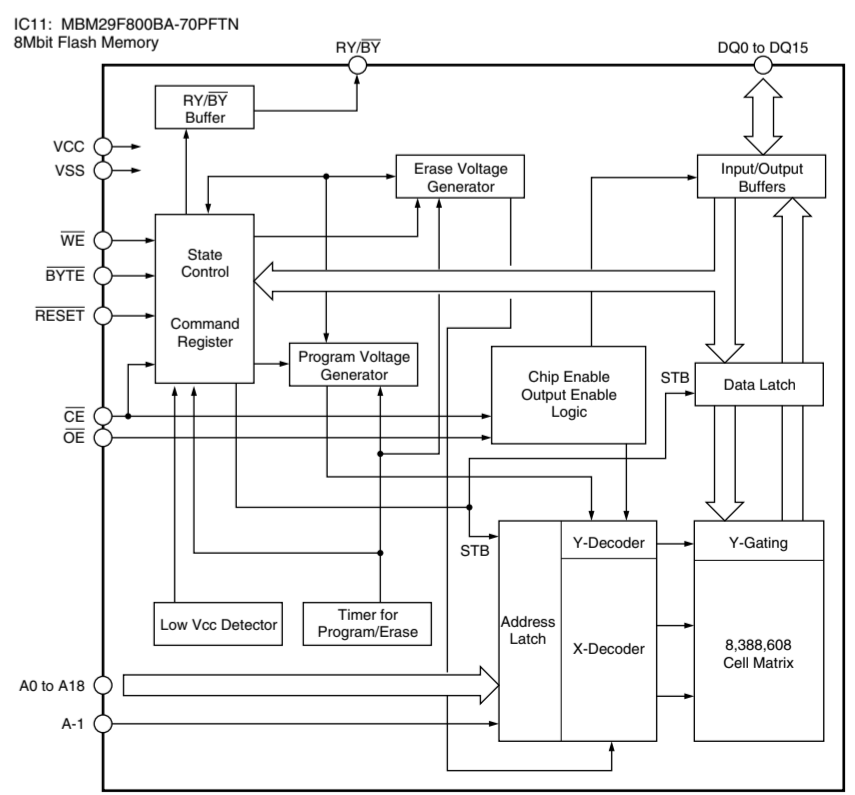

Table listing capacitor types and part names: NO MARK ELECTROLYTIC CAPACITOR, TANTALUM CAPACITOR, CERAMIC TUBULAR CAPACITOR, POLYESTER FILM CAPACITOR, POLYSTYRENE FILM CAPACITOR, MICA CAPACITOR, POLYPROPYLENE FILM CAPACITOR, SEMI-CONDUCTIVE CERAMIC CAPACITOR, POLYETHYLENE SULFIDE FILM CAPACITOR.

Table listing resistor types and part names: NO MARK CARBON FILM RESISTOR, CARBON FILM RESISTOR (IP=10), METAL OXIDE FILM RESISTOR, METAL FILM RESISTOR, METAL PLATE RESISTOR, FIRE PROOF CARBON FILM RESISTOR, CEMENT HOLED RESISTOR, SEMI-VARIABLE RESISTOR, CHIP RESISTOR.



NOTICE (mode1) (J)..... JAPANESE (U)..... U.S.A. (C)..... CANADIAN (R)..... GENERAL (A)..... ALGERIAN (B)..... BRITISH (G)..... EUROPEAN (T)..... CHINA (L)..... SINGAPORE



All voltage are measured with a 10M /V DC electric volt meter. Components having special characteristics are marked with a triangle. Must be replaced with parts having specifications equal to those originally installed. Schematic diagram is subject to change without notice.

電圧は、内部抵抗10MΩの電圧計で測定したものです。●印のある部品は、安全性確保部品を示しています。部品の交換が必要な場合、パーツリストに記載されている部品を使用してください。●本回路図は標準回路図です。改良のため予告なく変更することがございます。

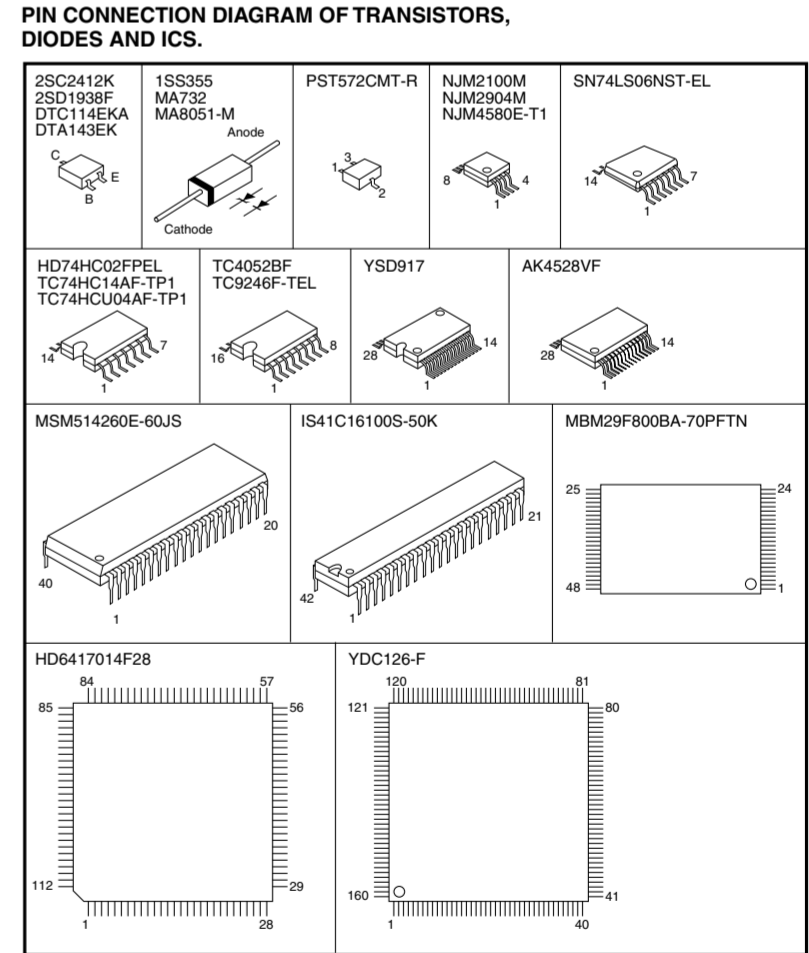
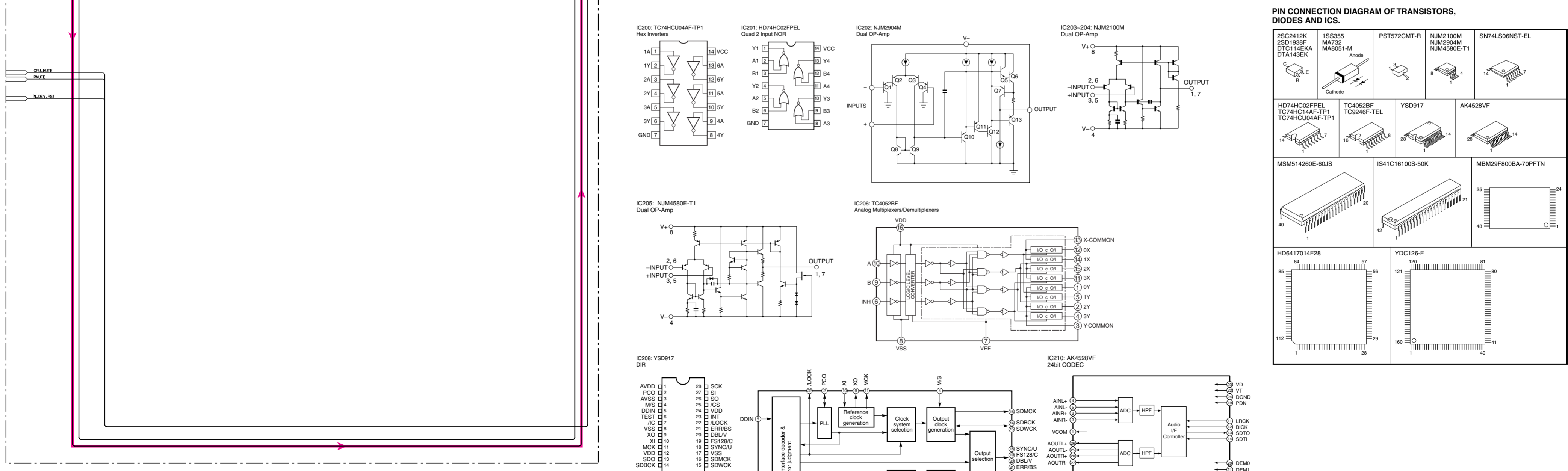
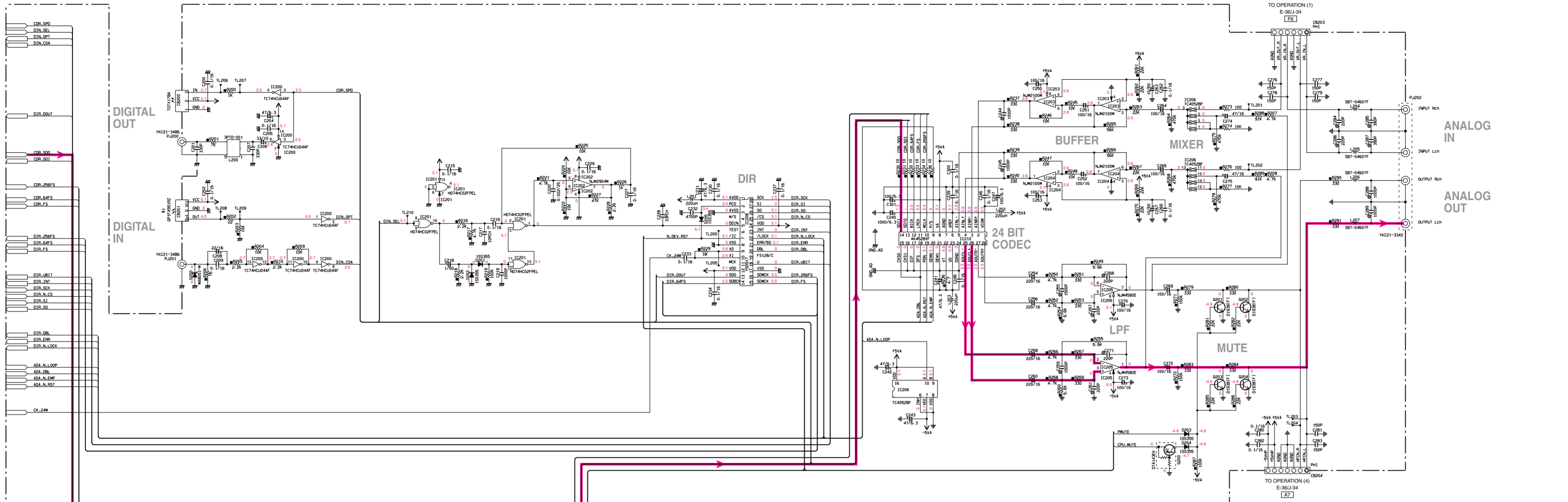

Interchangeable Parts at Manufacture Stage

Mark	Reference Parts Number	Parts Name
k1	CB001	GP1FA859RZ 10R4179
k2	IC7	M90614260E-60JS 1S41C1606-30K GL144016-40J4
k3	IC5	1S41C16100S-50K M90618100-60J-DR 1S41C16100-30K

RESISTOR

REMARKS	PARTS NAME
NO MARK	CARBON FILM RESISTOR (P=5)
□	CARBON FILM RESISTOR (P=10)
△	METAL OXIDE FILM RESISTOR
▲	METAL FILM RESISTOR
□	METAL PLATE RESISTOR
□	FIRE PROOF CARBON FILM RESISTOR
□	CEMENT MOLDED RESISTOR
□	SEMI VARIABLE RESISTOR
□	CHIP RESISTOR

CAPACITOR

REMARKS	PARTS NAME
NO MARK	ELECTROLYTIC CAPACITOR
□	TANTALUM CAPACITOR
NO MARK	CERAMIC CAPACITOR
●	CERAMIC TUBULAR CAPACITOR
○	POLYESTER FILM CAPACITOR
○	POLYSTYRENE FILM CAPACITOR
○	NICA CAPACITOR
○	POLYPROPYLENE FILM CAPACITOR
○	SEMICONDUCTIVE CERAMIC CAPACITOR
○	POLYPHENYLENE SULFIDE FILM CAPACITOR

NOTICE (mode1)

(J)..... JAPANESE
(U)..... U.S.A
(C)..... CANADIAN
(R)..... GENERAL
(A)..... AUSTRALIAN
(B)..... BRITISH
(G)..... EUROPEAN
(T)..... CHINA
(L)..... SINGAPORE

★ All voltage are measured with a 10M Ω /V DC electric volt meter.
★ Components having special characteristics are marked with a triangle and must be replaced with parts having specifications equal to those originally installed.
★ Schematic diagram is subject to change without notice.

● 電圧は、内部抵抗10MΩの電圧計で測定したものです。
● 印のある部品は、安全性確保部品を示しています。部品の交換が必要な場合、パーツリストに記載されている部品を使用してください。
● 本回路図は標準回路図です。改良のため予告なく変更することがございます。

SCHEMATIC DIAGRAM (OPERATION 1/2)

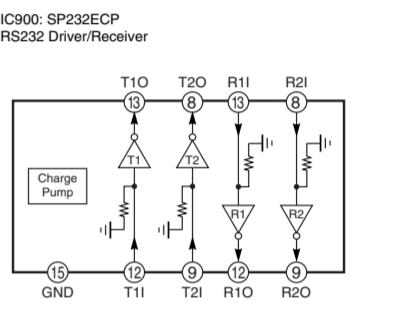
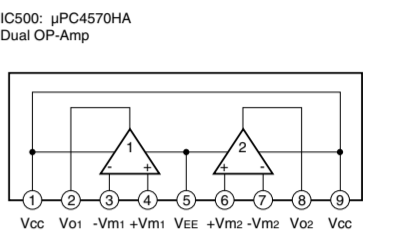
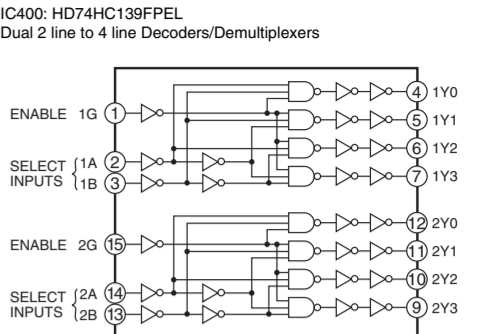
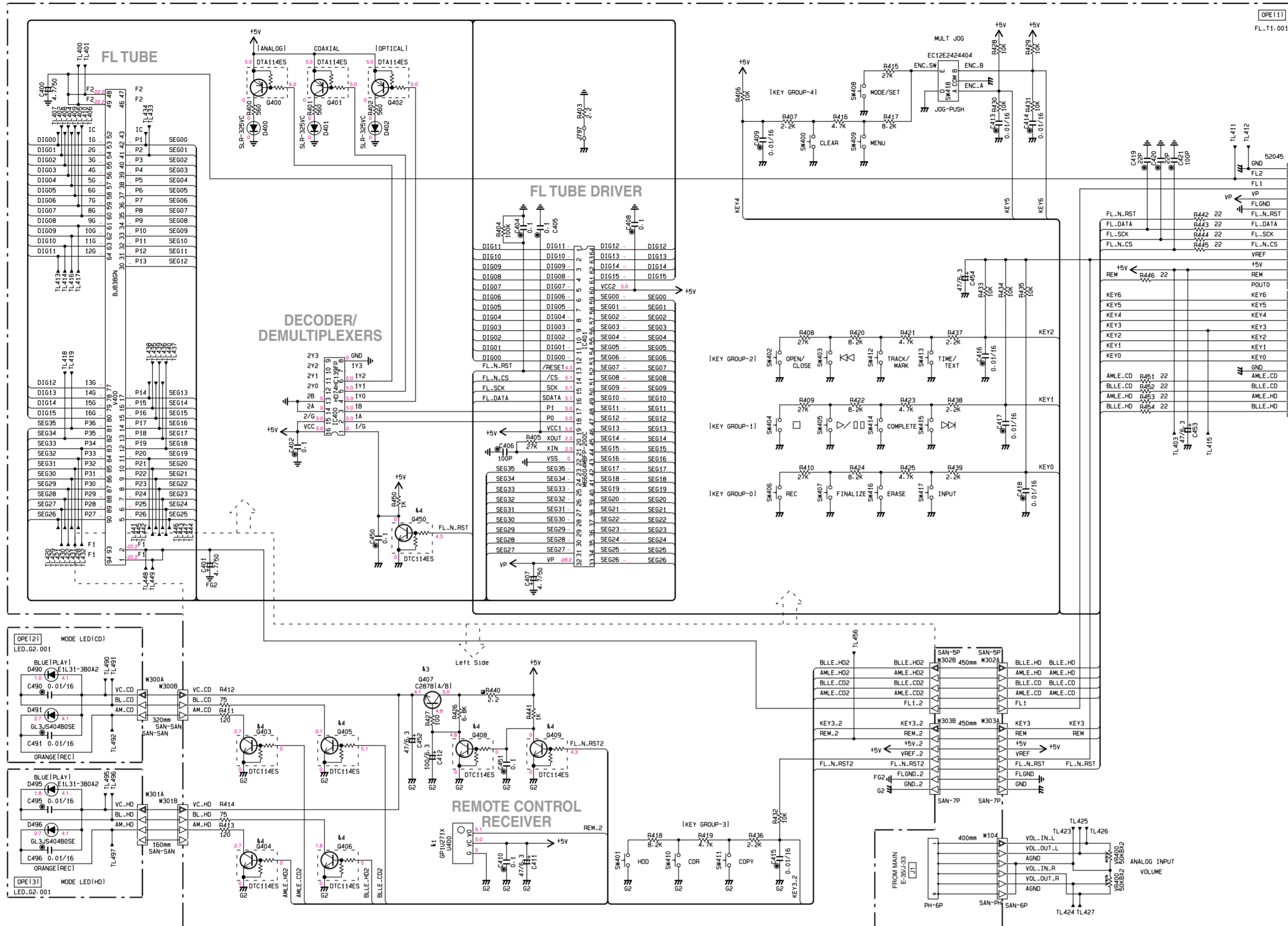

PIN CONNECTION DIAGRAM OF TRANSISTORS, DIODES AND ICs.

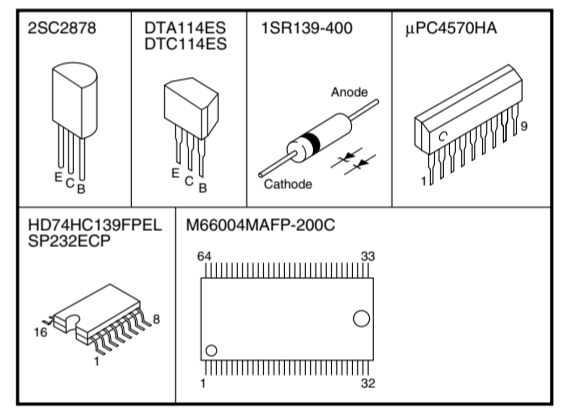

REMARKS	PARTS NAME	REMARKS	PARTS NAME
NO MARK	CARBON FILM RESISTOR (P=5)	NO MARK	ELECTROLYTIC CAPACITOR
□	CARBON FILM RESISTOR (P=10)	⊗	TANTALUM CAPACITOR
△	METAL OXIDE FILM RESISTOR	NO MARK	CERAMIC CAPACITOR
⊠	METAL FILM RESISTOR	⊙	CERAMIC TUBULAR CAPACITOR
⊞	METAL PLATE RESISTOR	⊚	POLYESTER FILM CAPACITOR
⊞	FIRE PROOF CARBON FILM RESISTOR	⊚	POLYSTYRENE FILM CAPACITOR
⊞	CEMENT MOLDED RESISTOR	⊚	MICA CAPACITOR
⊞	SEMI VARIABLE RESISTOR	⊚	POLYPROPYLENE FILM CAPACITOR
⊞	CHIP RESISTOR	⊚	SEMICONDUCTIVE CERAMIC CAPACITOR
		⊚	POLYPHENYLENE SULFIDE FILM CAPACITOR

NOTICE (mode1)
(J)..... JAPANESE
(U)..... U.S.A
(C)..... CANADIAN
(R)..... GENERAL
(A)..... AUSTRALIAN
(B)..... BRITISH
(G)..... EUROPEAN
(T)..... CHINA
(L)..... SINGAPORE

- ★ All voltage are measured with a 10M Ω DC electric volt meter.
- ★ Components having special characteristics are marked Δ and must be replaced with parts having specifications equal to those originally installed.
- ★ Schematic diagram is subject to change without notice.
- 電圧は、内部抵抗10M Ω の電圧計で測定したものです。
- Δ 印のある部品は、安全性確保部品を示しています。部品の交換が必要な場合、パーツリストに記載されている部品を使用してください。
- 本回路図は標準回路図です。改良のため予告なく変更することがございます。

CDR-HD1000
SCHEMATIC DIAGRAM (OPERATION 2/2)

Interchangeable Parts at Manufacture-Stage

Mark	Reference Parts Number	Parts Name
41	U400	GP1U271X PIC-28143TH5
42	0700.703	2SA933S(O/R) 2SA1115(E/F) 2SA1309A(O/R/S)
43	0407	2SC2878(A/B) 2SD1915F(S/T)
44	0403-406.408.409.450	DTC114ES UN4211

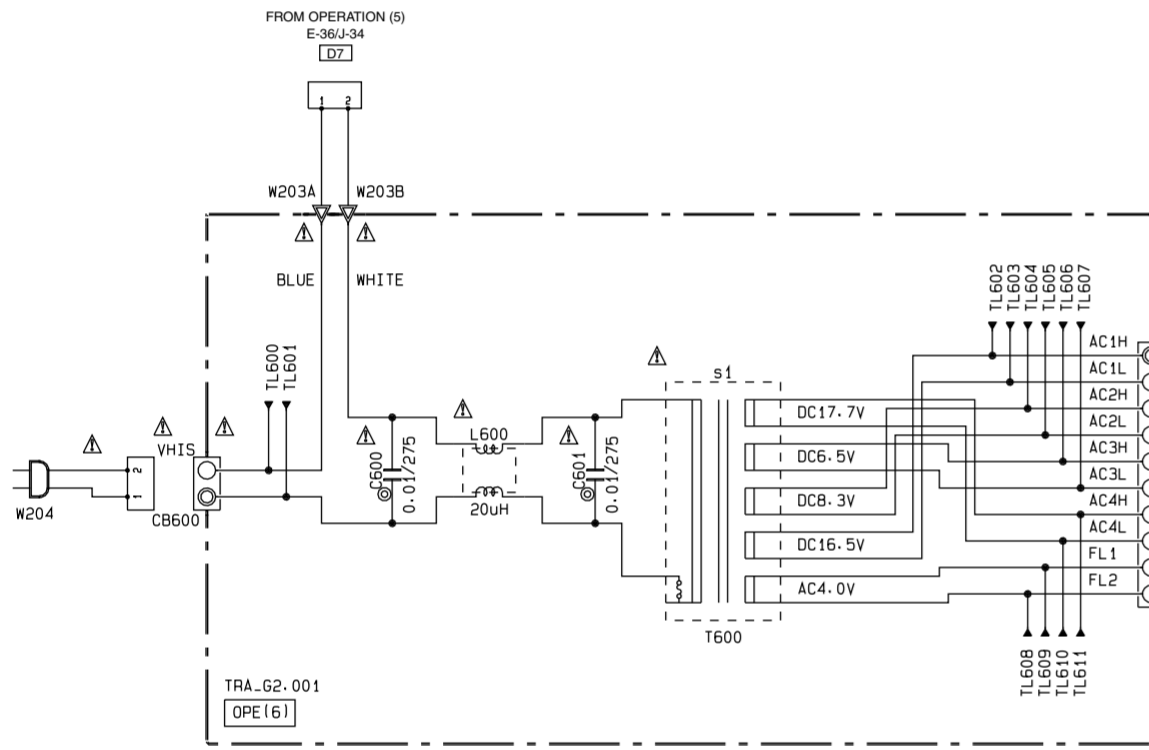

J	U-C	A	G
s1	XY619	X0211	X0213

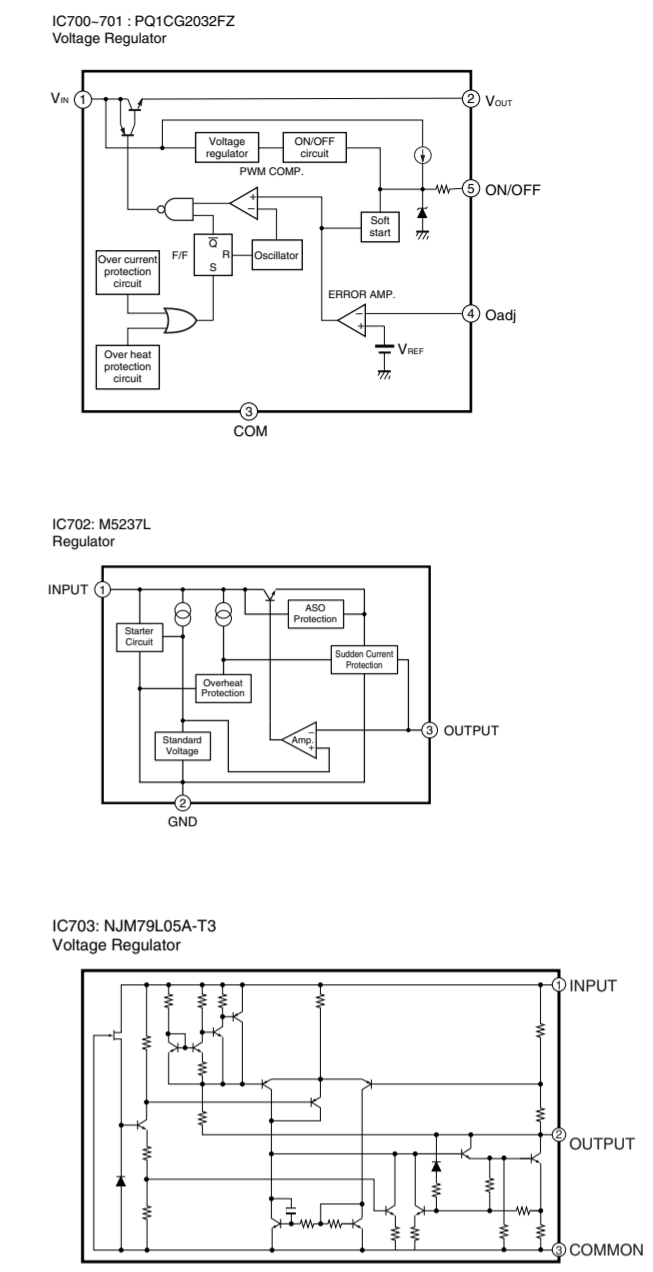
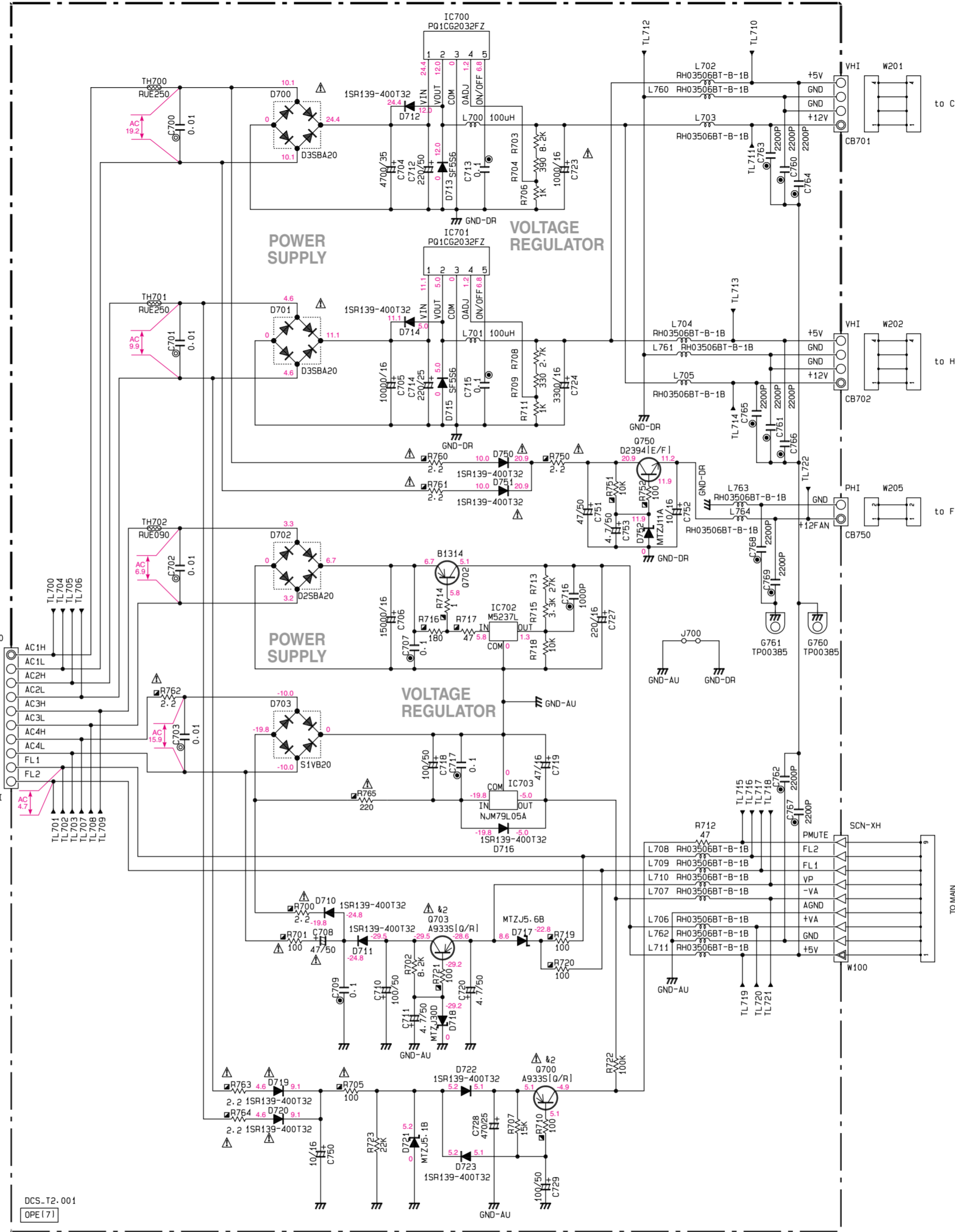

PIN CONNECTION DIAGRAM OF TRANSISTORS, DIODES AND ICs.

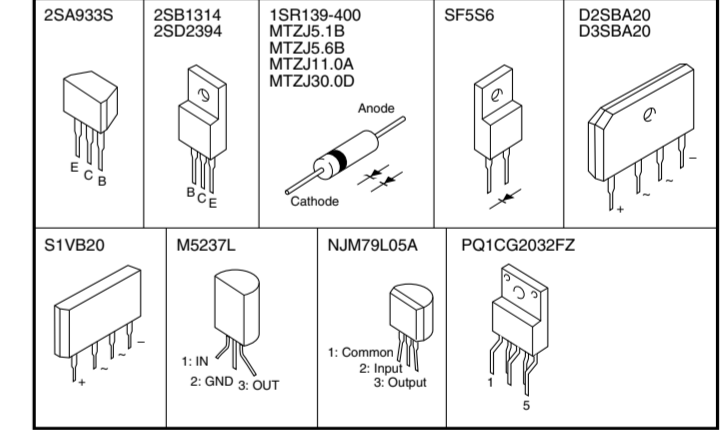

REMARKS	PARTS NAME
NO MARK	CARBON FILM RESISTOR (P=5)
□	CARBON FILM RESISTOR (P=10)
△	METAL OXIDE FILM RESISTOR
⊠	METAL FILM RESISTOR
⊞	METAL PLATE RESISTOR
▣	FIRE PROOF CARBON FILM RESISTOR
□	CEMENT MOLDED RESISTOR
⊗	SEMI VARIABLE RESISTOR
■	CHIP RESISTOR

REMARKS	PARTS NAME
NO MARK	ELECTROLYTIC CAPACITOR
⊗	TANTALUM CAPACITOR
NO MARK	CERAMIC CAPACITOR
⊙	CERAMIC TUBULAR CAPACITOR
⊚	POLYESTER FILM CAPACITOR
○	POLYSTYRENE FILM CAPACITOR
⊖	MICA CAPACITOR
⊕	POLYPROPYLENE FILM CAPACITOR
⊗	SEMICONDUCTIVE CERAMIC CAPACITOR
⊙	POLYPHENYLENE SULFIDE FILM CAPACITOR

NOTICE (model)

(J)..... JAPANESE
 (U)..... U.S. A
 (C)..... CANADIAN
 (R)..... GENERAL
 (A)..... AUSTRALIAN
 (B)..... BRITISH
 (G)..... EUROPEAN
 (T)..... CHINA
 (L)..... SINGAPORE

- ★ All voltage are measured with a 10M Ω DC electric volt meter.
- ★ Components having special characteristics are marked ! and must be replaced with parts having specifications equal to those originally installed.
- ★ Schematic diagram is subject to change without notice.
- 電圧は、内部抵抗10MΩの電圧計で測定したものです。
- !印のある部品は、安全性確保部品を示しています。部品の交換が必要な場合、パーツリストに記載されている部品を使用してください。
- 本回路図は標準回路図です。改良のため予告なく変更することがございます。

PARTS LIST

■ ELECTRICAL PARTS

■ WARNING

Components having special characteristics are marked Δ and must be replaced with parts having specifications equal to those originally installed.

- Carbon resistors (1/6W or 1/4W) are not included in the ELECTRICAL PARTS List. For the parts No. of the carbon resistors, refer to last page.

ABBREVIATIONS IN THIS LIST ARE AS FOLLOWS:

C.A.EL.CHP	: CHIP ALUMI.ELECTROLYTIC CAP	L.EMIT	: LIGHT EMITTING MODULE
C.CE	: CERAMIC CAP	LED.DSPLY	: LED DISPLAY
C.CE.ARRAY	: CERAMIC CAP ARRAY	LED.INFRD	: LED,INFRARED
C.CE.CHP	: CHIP CERAMIC CAP	MODUL.RF	: MODULATOR,RF
C.CE.ML	: MULTILAYER CERAMIC CAP	PHOT.CPL	: PHOTO COUPLER
C.CE.M.CHP	: CHIP MULTILAYER CERAMIC CAP	PHOT.INTR	: PHOTO INTERRUPTER
C.CE.SAFTY	: RECOGNIZED CERAMIC CAP	PHOT.RFLCT	: PHOTO REFLECTOR
C.CE.TUBLR	: CERAMIC TUBULAR CAP	PIN.TEST	: PIN,TEST POINT
C.CE.SMI	: SEMI CONDUCTIVE CERAMIC CAP	PLST.RIVET	: PLASTIC RIVET
C.EL	: ELECTROLYTIC CAP	R.ARRAY	: RESISTOR ARRAY
C.MICA	: MICA CAP	R.CAR.	: CARBON RESISTOR
C.ML.FLM	: MULTILAYER FILM CAP	R.CAR.CHP	: CHIP RESISTOR
C.MP	: METALLIZED PAPER CAP	R.CAR.FP	: FLAME PROOF CARBON RESISTOR
C.MYLAR	: MYLAR FILM CAP	R.FUS	: FUSABLE RESISTOR
C.MYLAR.ML	: MULTILAYER MYLAR FILM CAP	R.MTL.CHP	: CHIP METAL FILM RESISTOR
C.PAPER	: PAPER CAPACITOR	R.MTL.FLM	: METAL FILM RESISTOR
C.PLS	: POLYSTYRENE FILM CAP	R.MTL.OXD	: METAL OXIDE FILM RESISTOR
C.POL	: POLYESTER FILM CAP	R.MTL.PLAT	: METAL PLATE RESISTOR
C.POLY	: POLYETHYLENE FILM CAP	RSNR.CE	: CERAMIC RESONATOR
C.PP	: POLYPROPYLENE FILM CAP	RSNR.CRYS	: CRYSTAL RESONATOR
C.TNTL	: TANTALUM CAP	R.TW.CEM	: TWIN CEMENT FIXED RESISTOR
C.TNTL.CHP	: CHIP TANTALUM CAP	R.WW	: WIRE WOUND RESISTOR
C.TRIM	: TRIMMER CAP	SCR.BND.HD	: BIND HEAD B-TITE SCREW
CN	: CONNECTOR	SCR.BW.HD	: BW HEAD TAPPING SCREW
CN.BS.PIN	: CONNECTOR,BASE PIN	SCR.CUP	: CUP TITE SCREW
CN.CANNON	: CONNECTOR,CANNON	SCR.TERM	: SCREW TERMINAL
CN.DIN	: CONNECTOR,DIN	SCR.TR	: SCREW,TRANSISTOR
CN.FLAT	: CONNECTOR,FLAT CABLE	SUPRT.PCB	: SUPPORT,P.C.B.
CN.POST	: CONNECTOR,BASE POST	SURG.PRTCT	: SURGE PROTECTOR
COIL.MX.AM	: COIL,AM MIX	SW.TACT	: TACT SWITCH
COIL.AT.FM	: COIL,FM ANTENNA	SW.LEAF	: LEAF SWITCH
COIL.DT.FM	: COIL,FM DETECT	SW.LEVER	: LEVER SWITCH
COIL.MX.FM	: COIL,FM MIX	SW.MICRO	: MICRO SWITCH
COIL.OUTPT	: OUTPUT COIL	SW.PUSH	: PUSH SWITCH
DIOD.ARRAY	: DIODE ARRAY	SW.RT.ENC	: ROTARY ENCODER
DIODE.BRG	: DIODE BRIDGE	SW.RT.MTR	: ROTARY SWITCH WITH MOTOR
DIODE.CHP	: CHIP DIODE	SW.RT	: ROTARY SWITCH
DIODE.SHOT	: SCHOTTKY BARRIER DIODE	SW.SLIDE	: SLIDE SWITCH
DIODE.VAR	: VARACTOR DIODE	TERM.SP	: SPEAKER TERMINAL
DIOD.Z.CHP	: CHIP ZENER DIODE	TERM.WRAP	: WRAPPING TERMINAL
DIODE.ZENR	: ZENER DIODE	THRMST.CHP	: CHIP THERMISTOR
DSCR.CE	: CERAMIC DISCRIMINATOR	TR.CHP	: CHIP TRANSISTOR
FER.BEAD	: FERRITE BEADS	TR.DGT	: DIGITAL TRANSISTOR
FER.CORE	: FERRITE CORE	TR.DGT.CHP	: CHIP DIGITAL TRANSISTOR
FET.CHP	: CHIP FET	TRANS	: TRANSFORMER
FL.DSPLY	: FLUORESCENT DISPLAY	TRANS.PULS	: PULSE TRANSFORMER
FLTR.CE	: CERAMIC FILTER	TRANS.PWR	: POWER TRANSFORMER ASS'Y
FLTR.COMB	: COMB FILTER MODULE	TUNER.AM	: TUNER PACK,AM
FLTR.LC.RF	: LC FILTER,EMI	TUNER.FM	: TUNER PACK,FM
GND.MTL	: GROUND PLATE	TUNER.PK	: FRONT-END TUNER PACK
GND.TERM	: GROUND TERMINAL	VR	: ROTARY POTENTIOMETER
HOLDER.FUS	: FUSE HOLDER	VR.MTR	: POTENTIOMETER WITH MOTOR
IC.PRTCT	: IC PROTECTOR	VR.SW	: POTENTIOMETER WITH ROTARY SW
JUMPER.CN	: JUMPER CONNECTOR	VR.SLIDE	: SLIDE POTENTIOMETER
JUMPER.TST	: JUMPER,TEST POINT	VR.TRIM	: TRIMMER POTENTIOMETER
L.DTCT	: LIGHT DETECTING MODULE		

Note) Those parts marked with “#” are not included in the P.C.B. ass'y.

P.C.B. OPERATION

Schm Ref.	PART NO.	Description	Markets
	V7455000	P. C. B.	OPERATION
CB400	VP082900	CN. BS. PIN	25P
CB550	VP245600	CN	2P
CB600	VG879900	CN. BS. PIN	2P
CB601	LB933100	CN. BS. PIN	10P SE
CB700	LB932100	CN. BS. PIN	10P
CB701	LB932040	CN. BS. PIN	4P
CB702	LB932040	CN. BS. PIN	4P
CB750	VB389800	CN. BS. PIN	2P
CB901	V6509500	SOCKET	9P SE 3170
C400	UM416470	C. EL	4.7uF 50V
C401	UM416470	C. EL	4.7uF 50V
C402	VJ599100	C. CE. TUBLR	0.1uF 50V
C404	VJ599100	C. CE. TUBLR	0.1uF 50V
C405	VJ599100	C. CE. TUBLR	0.1uF 50V
C406	VF466800	C. CE. TUBLR	100pF 50V
C407	UM416470	C. EL	4.7uF 50V
C408	VJ599100	C. CE. TUBLR	0.1uF 50V
C409	VF467300	C. CE. TUBLR	0.01uF 16V
C410	VJ599100	C. CE. TUBLR	0.1uF 50V
C411	UM387470	C. EL	47uF 16V
C412	UM388100	C. EL	100uF 10V
C413	VF467300	C. CE. TUBLR	0.01uF 16V
C414	VF467300	C. CE. TUBLR	0.01uF 16V
C415	VF467300	C. CE. TUBLR	0.01uF 16V
C416	VF467300	C. CE. TUBLR	0.01uF 16V
C417	VF467300	C. CE. TUBLR	0.01uF 16V
C418	VF467300	C. CE. TUBLR	0.01uF 16V
C419	VG276600	C. CE. TUBLR	22pF 50V
C420	VG276600	C. CE. TUBLR	22pF 50V
C421	VF466800	C. CE. TUBLR	100pF 50V
C450	VJ599100	C. CE. TUBLR	0.1uF 50V
C451	VJ599100	C. CE. TUBLR	0.1uF 50V
C452	UM387470	C. EL	47uF 16V
C453	UM387470	C. EL	47uF 16V
C454	UM387470	C. EL	47uF 16V
C490	VF467300	C. CE. TUBLR	0.01uF 16V
C491	VF467300	C. CE. TUBLR	0.01uF 16V
C495	VF467300	C. CE. TUBLR	0.01uF 16V
C496	VF467300	C. CE. TUBLR	0.01uF 16V
C500	UR837470	C. EL	47uF 16V
C501	UR837470	C. EL	47uF 16V
C502	UR838330	C. EL	330uF 16V
C503	UA653220	C. MYLAR	2200pF 50V
C504	UA653220	C. MYLAR	2200pF 50V
C505	VG278200	C. CE. TUBLR	150pF 50V
C506	UR838330	C. EL	330uF 16V
C550	V3501400	C. CE. SAFTY	0.01uF 275V
C600	V3501400	C. CE. SAFTY	0.01uF 275V
C601	V3501400	C. CE. SAFTY	0.01uF 275V
C700	UA654100	C. MYLAR	0.01uF 50V
C701	UA654100	C. MYLAR	0.01uF 50V
C702	UA654100	C. MYLAR	0.01uF 50V
C703	UA654100	C. MYLAR	0.01uF 50V
C704	UR759470	C. EL	4700uF 35V
C705	UR73A100	C. EL	10000uF 16V
C706	V8225900	C. EL	15000uF 16V
C707	VJ599100	C. CE. TUBLR	0.1uF 50V
C708	UR867470	C. EL	47uF 50V
C709	VJ599100	C. CE. TUBLR	0.1uF 50V
C710	UR868100	C. EL	100uF 50V
C711	UR866470	C. EL	4.7uF 50V
C712	UR868220	C. EL	220uF 50V

Schm Ref.	PART NO.	Description	Markets
C713	VJ599100	C. CE. TUBLR	0.1uF 50V
C714	UR848220	C. EL	220uF 25V
C715	VJ599100	C. CE. TUBLR	0.1uF 50V
C716	VF467000	C. CE. TUBLR	1000pF 50V
C717	VJ599100	C. CE. TUBLR	0.1uF 50V
C718	UR868100	C. EL	100uF 50V
C719	UR837470	C. EL	47uF 16V
C720	UR866470	C. EL	4.7uF 50V
C723	UR839100	C. EL	1000uF 16V
C724	UR739330	C. EL	3300uF 16V
C727	UR838220	C. EL	220uF 16V
C728	UR848470	C. EL	470uF 25V
C729	UR868100	C. EL	100uF 50V
C750	UR837100	C. EL	10uF 16V
C751	UR867470	C. EL	47uF 50V
C752	UR837100	C. EL	10uF 16V
C753	UR866470	C. EL	4.7uF 50V
C760	VG279400	C. CE. TUBLR	2200pF 16V
C761	VG279400	C. CE. TUBLR	2200pF 16V
C762	VG279400	C. CE. TUBLR	2200pF 16V
C763	VG279400	C. CE. TUBLR	2200pF 16V
C764	VG279400	C. CE. TUBLR	2200pF 16V
C765	VG279400	C. CE. TUBLR	2200pF 16V
C766	VG279400	C. CE. TUBLR	2200pF 16V
C767	VG279400	C. CE. TUBLR	2200pF 16V
C768	VG279400	C. CE. TUBLR	2200pF 16V
C769	VG279400	C. CE. TUBLR	2200pF 16V
C900	VJ599100	C. CE. TUBLR	0.1uF 50V
C901	UR818100	C. EL	100uF 6.3V
C902	VJ599100	C. CE. TUBLR	0.1uF 50V
C903	VJ599100	C. CE. TUBLR	0.1uF 50V
C904	VJ599100	C. CE. TUBLR	0.1uF 50V
C905	VG278100	C. CE. TUBLR	120pF 50V
D400	VS132300	LED(re)	SLR-325VCT31
D401	VS132300	LED(re)	SLR-325VCT31
D402	VS132300	LED(re)	SLR-325VCT31
D490	V7446300	LED	E1L31-3B0A2
D491	V7446400	LED	GL3JS404B0SE
D495	V7446300	LED	E1L31-3B0A2
D496	V7446400	LED	GL3JS404B0SE
D500	VU264100	DIODE	1SR139-400
D501	VU264100	DIODE	1SR139-400
D700	VN011300	DIODE.BRG	D3SBA20 4A 200V
D701	VN011300	DIODE.BRG	D3SBA20 4A 200V
D702	V4269600	DIODE.BRG	D2SBA20 1.5A 200V
D703	VQ379300	DIODE.BRG	S1VB20 1.0A 200V
D710	VU264100	DIODE	1SR139-400
D711	VU264100	DIODE	1SR139-400
D712	VU264100	DIODE	1SR139-400
D713	V6591700	DIODE	SF5S6
D714	VU264100	DIODE	1SR139-400
D715	V6591700	DIODE	SF5S6
D716	VU264100	DIODE	1SR139-400
D717	VG437700	DIODE.ZENR	MTZJ5.6B 5.6V
D718	VG443500	DIODE.ZENR	MTZJ30D 30V
D719	VU264100	DIODE	1SR139-400
D720	VU264100	DIODE	1SR139-400
D721	VG437400	DIODE.ZENR	MTZJ5.1B 5.1V
D722	VU264100	DIODE	1SR139-400
D723	VU264100	DIODE	1SR139-400
D750	VU264100	DIODE	1SR139-400
D751	VU264100	DIODE	1SR139-400
D752	VG439800	DIODE.ZENR	MTZJ11A

* New Parts

* New Parts

P.C.B.OPERATION & P.C.B. MAIN

Schm Ref.	PART NO.	Description	Markets
G760	VR463400	TERM. GND	D3.5
G761	VR463400	TERM. GND	D3.5
HS700	V6295800	HEAT. SINK	PUH26-30
IC400	XU532A00	IC	HD74HC139FPEL 2-4
IC401	XY115A00	IC	M66004MAFP-200C
IC500	XB247A00	IC	uPC4570HA
IC700	XY525A00	IC	PQ1CG2032FZ
IC701	XY525A00	IC	PQ1CG2032FZ
IC702	Xi165A00	IC	M5237L
IC703	XP264A00	IC	NJM79L05A-T3
IC900	X0226A00	IC	SP232ECP
JK500	V5129000	JACK. PHONE	YKB26-5236
L500	VD473700	COIL	60uH
L501	VD473700	COIL	60uH
L502	VD473700	COIL	60uH
L503	Vi491100	FER. CORE	BP53RB19012080M
L600	VV900900	FLTR	3071-012-0
L700	V6673100	COIL	3145-044-0Y01
L701	V6673100	COIL	3145-044-0Y01
L702	V4769500	FER. BEAD	RH03506BT-B-1B
L703	V4769500	FER. BEAD	RH03506BT-B-1B
L704	V4769500	FER. BEAD	RH03506BT-B-1B
L705	V4769500	FER. BEAD	RH03506BT-B-1B
L706	V4769500	FER. BEAD	RH03506BT-B-1B
L707	V4769500	FER. BEAD	RH03506BT-B-1B
L708	V4769500	FER. BEAD	RH03506BT-B-1B
L709	V4769500	FER. BEAD	RH03506BT-B-1B
L710	V4769500	FER. BEAD	RH03506BT-B-1B
L711	V4769500	FER. BEAD	RH03506BT-B-1B
L760	V4769500	FER. BEAD	RH03506BT-B-1B
L761	V4769500	FER. BEAD	RH03506BT-B-1B
L762	V4769500	FER. BEAD	RH03506BT-B-1B
L763	V4769500	FER. BEAD	RH03506BT-B-1B
L764	V4769500	FER. BEAD	RH03506BT-B-1B
L900	VS150200	FLTR. LC. RF	ST B101KBTBM
L901	VS150200	FLTR. LC. RF	ST B101KBTBM
L902	Vi491100	FER. CORE	BP53RB19012080M
PN400	V3750100	PIN	L=50
PN401	V3750100	PIN	L=50
PN402	V3750100	PIN	L=50
PN403	V3750100	PIN	L=50
PN500	V3750100	PIN	L=50
PN600	V3750200	PIN	L=70
PN700	V3750200	PIN	L=70
PN701	V3750100	PIN	L=50
PN702	V3750100	PIN	L=50
PN900	V3750100	PIN	L=50
Q400	VD678500	TR. DGT	DTA114ES
Q401	VD678500	TR. DGT	DTA114ES
Q402	VD678500	TR. DGT	DTA114ES
Q403	VD678700	TR. DGT	DTC114ES
Q404	VD678700	TR. DGT	DTC114ES
Q405	VD678700	TR. DGT	DTC114ES
Q406	VD678700	TR. DGT	DTC114ES
Q407	iC287820	TR	2SC2878 A,B
Q408	VD678700	TR. DGT	DTC114ES
Q409	VD678700	TR. DGT	DTC114ES
Q450	VD678700	TR. DGT	DTC114ES
Q700	iA093320	TR	2SA933S Q,R
Q702	V2650900	TR	2SB1314 E,F
Q703	iA093320	TR	2SA933S Q,R
Q750	VS883400	TR	2SD2394 E,F
R440	HV753220	R. CAR. FP	2.2 1/4W

* New Parts

Schm Ref.	PART NO.	Description	Markets
R500	HV755100	R. CAR. FP	100 1/4W
R509	HV755100	R. CAR. FP	100 1/4W
R700	HV753220	R. CAR. FP	2.2 1/4W
R701	HV755100	R. CAR. FP	100 1/4W
R705	HV755100	R. CAR. FP	100 1/4W
R710	HV755100	R. CAR. FP	100 1/4W
R714	HV753100	R. CAR. FP	1 1/4W
R716	HV755180	R. CAR. FP	180 1/4W
R717	HV754470	R. CAR. FP	47 1/4W
R719	HV755100	R. CAR. FP	100 1/4W
R720	HV755100	R. CAR. FP	100 1/4W
R721	HV755100	R. CAR. FP	100 1/4W
R750	HV753220	R. CAR. FP	2.2 1/4W
R751	HV757100	R. CAR. FP	10K 1/4W
R752	HV755100	R. CAR. FP	100 1/4W
R760	HV753220	R. CAR. FP	2.2 1/4W
R761	HV753220	R. CAR. FP	2.2 1/4W
R762	HV753220	R. CAR. FP	2.2 1/4W
R763	HV753220	R. CAR. FP	2.2 1/4W
R764	HV753220	R. CAR. FP	2.2 1/4W
R765	HV755220	R. CAR. FP	220 1/4W
R900	HV753100	R. CAR. FP	1 1/4W
SW400	VG392900	SW. TACT	SKHVAA
SW401	VG392900	SW. TACT	SKHVAA
SW402	VG392900	SW. TACT	SKHVAA
SW403	VG392900	SW. TACT	SKHVAA
SW404	VG392900	SW. TACT	SKHVAA
SW405	VG392900	SW. TACT	SKHVAA
SW406	VG392900	SW. TACT	SKHVAA
SW407	VG392900	SW. TACT	SKHVAA
SW408	VG392900	SW. TACT	SKHVAA
SW409	VG392900	SW. TACT	SKHVAA
SW410	VG392900	SW. TACT	SKHVAA
SW411	VG392900	SW. TACT	SKHVAA
SW412	VG392900	SW. TACT	SKHVAA
SW413	VG392900	SW. TACT	SKHVAA
SW414	VG392900	SW. TACT	SKHVAA
SW415	VG392900	SW. TACT	SKHVAA
SW416	VG392900	SW. TACT	SKHVAA
SW417	VG392900	SW. TACT	SKHVAA
SW418	V7597700	SW. RT. ENC	EC12E2424404
SW550	VZ364100	SW. PUSH	SDDL1-A2-F-1
TH700	VV458000	SW	RUE250 2.50A 30V
TH701	VV458000	SW	RUE250 2.50A 30V
TH702	VV457600	SW	RUE090 0.90A 30V
U400	VU591000	L. DTCT	GP1U271X
V400	V7446200	FL. DSPLY	BJ838GN
VR400	V6619600	VR	B50K RK14K12C0
VR500	V7502400	VR	A20K RK09L12B0
	VQ859800	SHEET. FL	
	V8080700	SPACER. FL	
	V6100600	SUPRT	
	EG330030	SCR. BND. HD	3x6 MFCR3BL
	V8297500	SPACER. LED	
	V7454900	P. C. B.	MAIN
CB1	V4325300	CN	2P
CB2	VL845300	CN. BS. PIN	9P
CB3	VP082900	CN. BS. PIN	25P
CB4	V6451700	CN. BS. PIN	16P TE
CB5	VB389800	CN. BS. PIN	2P

* New Parts

P.C.B. MAIN

Schm Ref.	PART NO.	Description	Markets
CB140	VB390000	CN.BS.PIN	4P
CB200	V4164300	L.EMIT	TOTX178A
CB201	V5478200	CN.PHOT.SN	1P GP1FA551RZ
CB203	VB390200	CN.BS.PIN	6P
CB204	VB390300	CN.BS.PIN	7P
C1	US061330	C.CE.M.CHP	33pF 50V
C2	US061330	C.CE.M.CHP	33pF 50V
C3	US061330	C.CE.M.CHP	33pF 50V
C4	US061330	C.CE.M.CHP	33pF 50V
C5	US061330	C.CE.M.CHP	33pF 50V
C6	US061330	C.CE.M.CHP	33pF 50V
C7	US061330	C.CE.M.CHP	33pF 50V
C8	US061330	C.CE.M.CHP	33pF 50V
C9	US061330	C.CE.M.CHP	33pF 50V
C10	US061330	C.CE.M.CHP	33pF 50V
C11	US061330	C.CE.M.CHP	33pF 50V
C12	US061330	C.CE.M.CHP	33pF 50V
C13	US061330	C.CE.M.CHP	33pF 50V
C14	US061330	C.CE.M.CHP	33pF 50V
C15	US061330	C.CE.M.CHP	33pF 50V
C16	US061330	C.CE.M.CHP	33pF 50V
C17	US135100	C.CE.CHP	0.1uF 16V
C18	UF017470	C.EL.CHP	47uF 6.3V
C19	US063100	C.CE.M.CHP	1000pF 50V
C20	US063100	C.CE.M.CHP	1000pF 50V
C21	US063100	C.CE.M.CHP	1000pF 50V
C22	US063100	C.CE.M.CHP	1000pF 50V
C23	US063100	C.CE.M.CHP	1000pF 50V
C24	US063100	C.CE.M.CHP	1000pF 50V
C25	US063100	C.CE.M.CHP	1000pF 50V
C26	US063100	C.CE.M.CHP	1000pF 50V
C27	US063100	C.CE.M.CHP	1000pF 50V
C28	US063100	C.CE.M.CHP	1000pF 50V
C29	US061330	C.CE.M.CHP	33pF 50V
C30	US061330	C.CE.M.CHP	33pF 50V
C31	US061330	C.CE.M.CHP	33pF 50V
C32	US061330	C.CE.M.CHP	33pF 50V
C33	US061330	C.CE.M.CHP	33pF 50V
C34	US061330	C.CE.M.CHP	33pF 50V
C35	US061330	C.CE.M.CHP	33pF 50V
C36	US061330	C.CE.M.CHP	33pF 50V
C37	US061330	C.CE.M.CHP	33pF 50V
C38	US061330	C.CE.M.CHP	33pF 50V
C39	US061330	C.CE.M.CHP	33pF 50V
C40	US061330	C.CE.M.CHP	33pF 50V
C41	US061330	C.CE.M.CHP	33pF 50V
C42	US061330	C.CE.M.CHP	33pF 50V
C43	US061330	C.CE.M.CHP	33pF 50V
C44	US061330	C.CE.M.CHP	33pF 50V
C45	US061330	C.CE.M.CHP	33pF 50V
C46	US135100	C.CE.CHP	0.1uF 16V
C47	UF017470	C.EL.CHP	47uF 6.3V
C48	US061150	C.CE.CHP	15pF 50V
C49	US061150	C.CE.CHP	15pF 50V
C50	US063100	C.CE.M.CHP	1000pF 50V
C51	US063100	C.CE.M.CHP	1000pF 50V
C52	US063100	C.CE.M.CHP	1000pF 50V
C53	US063100	C.CE.M.CHP	1000pF 50V
C54	US063100	C.CE.M.CHP	1000pF 50V
C55	US063100	C.CE.M.CHP	1000pF 50V
C56	UF017470	C.EL.CHP	47uF 6.3V
C57	US135100	C.CE.CHP	0.1uF 16V
C58	US135100	C.CE.CHP	0.1uF 16V

* New Parts

Schm Ref.	PART NO.	Description	Markets
C59	US135100	C.CE.CHP	0.1uF 16V
C60	US062470	C.CE.M.CHP	470pF 50V
C61	US061270	C.CE.M.CHP	27pF 50V
C62	US061270	C.CE.M.CHP	27pF 50V
C63	US135100	C.CE.CHP	0.1uF 16V
C64	US063100	C.CE.M.CHP	1000pF 50V
C65	UR819100	C.EL	1000uF 6.3V
C66	US135100	C.CE.CHP	0.1uF 16V
C67	UF017470	C.EL.CHP	47uF 6.3V
C68	US061150	C.CE.CHP	15pF 50V
C69	US061150	C.CE.CHP	15pF 50V
C70	US135100	C.CE.CHP	0.1uF 16V
C71	US135100	C.CE.CHP	0.1uF 16V
C72	US135100	C.CE.CHP	0.1uF 16V
C73	US135100	C.CE.CHP	0.1uF 16V
C74	US135100	C.CE.CHP	0.1uF 16V
C75	US135100	C.CE.CHP	0.1uF 16V
C76	US135100	C.CE.CHP	0.1uF 16V
C77	US135100	C.CE.CHP	0.1uF 16V
C78	US135100	C.CE.CHP	0.1uF 16V
C79	US135100	C.CE.CHP	0.1uF 16V
C80	US135100	C.CE.CHP	0.1uF 16V
C81	US135100	C.CE.CHP	0.1uF 16V
C82	UF037100	C.EL.CHP	10uF 16V
C83	US063100	C.CE.M.CHP	1000pF 50V
C84	US135100	C.CE.CHP	0.1uF 16V
C85	US135100	C.CE.CHP	0.1uF 16V
C86	US135100	C.CE.CHP	0.1uF 16V
C88	US135100	C.CE.CHP	0.1uF 16V
C89	US135100	C.CE.CHP	0.1uF 16V
C90	US135100	C.CE.CHP	0.1uF 16V
C91	US135100	C.CE.CHP	0.1uF 16V
C92	US135100	C.CE.CHP	0.1uF 16V
C93	UF017470	C.EL.CHP	47uF 6.3V
C94	US063100	C.CE.M.CHP	1000pF 50V
C95	US063100	C.CE.M.CHP	1000pF 50V
C96	US063100	C.CE.M.CHP	1000pF 50V
C97	US135100	C.CE.CHP	0.1uF 16V
C98	UF018100	C.EL.CHP	100uF 6.3V
C99	US135100	C.CE.CHP	0.1uF 16V
C100	US163100	C.CE.CHP	1000pF 50V
C101	VR169200	C.MYLAR.ML	ECQ-V1H474JL3
C102	US062100	C.CE.M.CHP	100pF 50V
C103	US135100	C.CE.CHP	0.1uF 16V
C104	US063470	C.CE.CHP	4700pF 50V
C140	US135100	C.CE.CHP	0.1uF 16V
C141	US135100	C.CE.CHP	0.1uF 16V
C142	US135100	C.CE.CHP	0.1uF 16V
C143	US135100	C.CE.CHP	0.1uF 16V
C144	UF017470	C.EL.CHP	47uF 6.3V
C145	US061100	C.CE.M.CHP	10pF 50V
C200	US135100	C.CE.CHP	0.1uF 16V
C201	US062330	C.CE.M.CHP	330pF 50V
C202	US135100	C.CE.CHP	0.1uF 16V
C204	UF017470	C.EL.CHP	47uF 6.3V
C205	US135100	C.CE.CHP	0.1uF 16V
C206	UF027330	C.EL.CHP	33uF 10V
C207	US062330	C.CE.M.CHP	330pF 50V
C208	UF037220	C.EL.CHP	22uF 16V
C209	US135100	C.CE.CHP	0.1uF 16V
C215	US135100	C.CE.CHP	0.1uF 16V
C216	US135100	C.CE.CHP	0.1uF 16V
C217	US061100	C.CE.M.CHP	10pF 50V

* New Parts

P.C.B. MAIN

Schm Ref.	PART NO.	Description	Markets
C218	UF066100	C. EL. CHP 1uF 50V	
C219	US063100	C. CE. M. CHP 1000pF 50V	
C220	US044220	C. CE. M. CHP 0.022uF 25V	
C227	US135100	C. CE. CHP 0.1uF 16V	
C228	US061330	C. CE. M. CHP 33pF 50V	
C229	US135100	C. CE. CHP 0.1uF 16V	
C230	US135100	C. CE. CHP 0.1uF 16V	
C231	UF017470	C. EL. CHP 47uF 6.3V	
C232	US063470	C. CE. CHP 4700pF 50V	
C233	US135100	C. CE. CHP 0.1uF 16V	
C234	US135100	C. CE. CHP 0.1uF 16V	
C237	US135100	C. CE. CHP 0.1uF 16V	
C239	US135100	C. CE. CHP 0.1uF 16V	
C240	VG286600	C. EL 1000uF 6.3V	
C241	UF017470	C. EL. CHP 47uF 6.3V	
C242	UF017470	C. EL. CHP 47uF 6.3V	
C243	UF017470	C. EL. CHP 47uF 6.3V	
C244	UA653100	C. MYLAR 1000pF 50V	
C245	UA653100	C. MYLAR 1000pF 50V	
C246	US135100	C. CE. CHP 0.1uF 16V	
C247	UF018100	C. EL. CHP 100uF 6.3V	
C248	US135100	C. CE. CHP 0.1uF 16V	
C250	VG287600	C. EL 100uF 25V	
C251	VG287600	C. EL 100uF 25V	
C252	VG287600	C. EL 100uF 25V	
C253	VG287600	C. EL 100uF 25V	
* C254	VG287700	C. EL 220uF 25V	
* C255	UA653150	C. MYLAR 1500pF 50V	
* C256	VG287700	C. EL 220uF 25V	
* C257	UA652220	C. MYLAR 220pF 50V	
* C258	VG287700	C. EL 220uF 25V	
* C259	UA653150	C. MYLAR 1500pF 50V	
* C260	VG287700	C. EL 220uF 25V	
C261	UA652220	C. MYLAR 220pF 50V	
C262	US135100	C. CE. CHP 0.1uF 16V	
C263	VG290900	C. EL 10uF 50V	
C264	VG287600	C. EL 100uF 25V	
C265	VG287600	C. EL 100uF 25V	
C266	US135100	C. CE. CHP 0.1uF 16V	
C267	VG290900	C. EL 10uF 50V	
C268	UA652220	C. MYLAR 220pF 50V	
C269	VG287600	C. EL 100uF 25V	
C270	VG287600	C. EL 100uF 25V	
C271	UA652220	C. MYLAR 220pF 50V	
C272	VG287600	C. EL 100uF 25V	
C273	VG287600	C. EL 100uF 25V	
C274	VG287500	C. EL 47uF 50V	
C275	VG287500	C. EL 47uF 50V	
C276	US062150	C. CE. CHP 150pF 50V	
C277	US062150	C. CE. CHP 150pF 50V	
C278	US062150	C. CE. CHP 150pF 50V	
C279	US062150	C. CE. CHP 150pF 50V	
C280	US135100	C. CE. CHP 0.1uF 16V	
C281	US062150	C. CE. CHP 150pF 50V	
C282	US135100	C. CE. CHP 0.1uF 16V	
C283	US062150	C. CE. CHP 150pF 50V	
* C284	UA652220	C. MYLAR 220pF 50V	
* C285	UA652390	C. MYLAR 390pF 50V	
* C286	UA652220	C. MYLAR 220pF 50V	
* C287	UA652390	C. MYLAR 390pF 50V	
C288	UA653100	C. MYLAR 1000pF 50V	
C289	UA653100	C. MYLAR 1000pF 50V	
C300	US135100	C. CE. CHP 0.1uF 16V	

* New Parts

Schm Ref.	PART NO.	Description	Markets
C301	UF018100	C. EL. CHP 100uF 6.3V	
D1	VQ721800	DIODE. CHP MA732	
D2	VT332900	DIODE 1SS355	
D200	VU992600	DIODE. ZENR MA8051-M 5.1V	
D201	VT332900	DIODE 1SS355	
D202	VT332900	DIODE 1SS355	
D203	VT332900	DIODE 1SS355	
D204	VT332900	DIODE 1SS355	
D205	VT332900	DIODE 1SS355	
* IC1	XP985A00	IC SN74LS06NSR INV/BU	
IC2	XU147A00	IC HD6417014F28 CPU	
* IC3	XZ073A00	IC YDC126-F	
* IC4	XL122A00	IC PST572CMT-R	
* IC5	XY707A00	IC IS41C16100S-50K	
IC7	XV077B00	IC MSM514260E-60JS	
* IC8	XD657A00	IC TC74HC14AF-TP1 SOP	
* IC9	XR339A00	IC TC9246F-TEL PLL	
* IC11	XO419B00	IC MBM29F800BA-70PFTN	
IC200	XD660A00	IC TC74HCU04AF-TP1	
IC201	XL091A00	IC HD74HC02FPEL NOR	
IC202	XR038A00	IC NJM2904M OP AMP	
IC203	XQ185A00	IC NJM2100M	
IC204	XQ185A00	IC NJM2100M	
IC205	XQ178A00	IC NJM4580E-T1 OP AMP	
IC206	XG903A00	IC TC4052BF MPX	
IC208	XW526A00	IC YSD917	
* IC210	XY624A00	IC AK4528VF	
* L1	VY657500	COIL. CHP 120uH	
* L2	VR355700	COIL. CHP 220uH	
* L3	VR355700	COIL. CHP 220uH	
* L200	Vi530800	TRANS. PULS 3PTD-001	
* L201	VR355700	COIL. CHP 220uH	
* L202	VR355700	COIL. CHP 220uH	
* L203	VR355700	COIL. CHP 220uH	
L204	VD473700	COIL 60uH	
L205	VD473700	COIL 60uH	
L206	VD473700	COIL 60uH	
L207	VD473700	COIL 60uH	
* PJ200	V4846000	JACK. PIN 1P	
* PJ201	V4846000	JACK. PIN 1P	
PJ202	V2020500	JACK. PIN 4P	
Q1	VV556400	TR 2SC2412K Q, R, S	
Q2	VV655400	TR. DGT DTC114EKA	
Q200	VC123900	TR. DGT DTA143EK	
Q201	VZ725900	TR 2SD1938F S, T	
Q202	VZ725900	TR 2SD1938F S, T	
Q203	VZ725900	TR 2SD1938F S, T	
Q204	VZ725900	TR 2SD1938F S, T	
R1	HV753220	R. CAR. FP 2.2 1/4W	
R2	HV753220	R. CAR. FP 2.2 1/4W	
R155	HV753220	R. CAR. FP 2.2 1/4W	
R236	HV753470	R. CAR. FP 4.7 1/4W	
* TE1	V5739200	CN. BS. PIN 2120-40SF1BN	
XL1	VV762900	RSNR. CRY 7MHz SMD-49	
XL2	V3625700	RSNR. CRY 24.576MHz	

* New Parts

1

EXPLODED VIEW

2

3

4

5

6

7

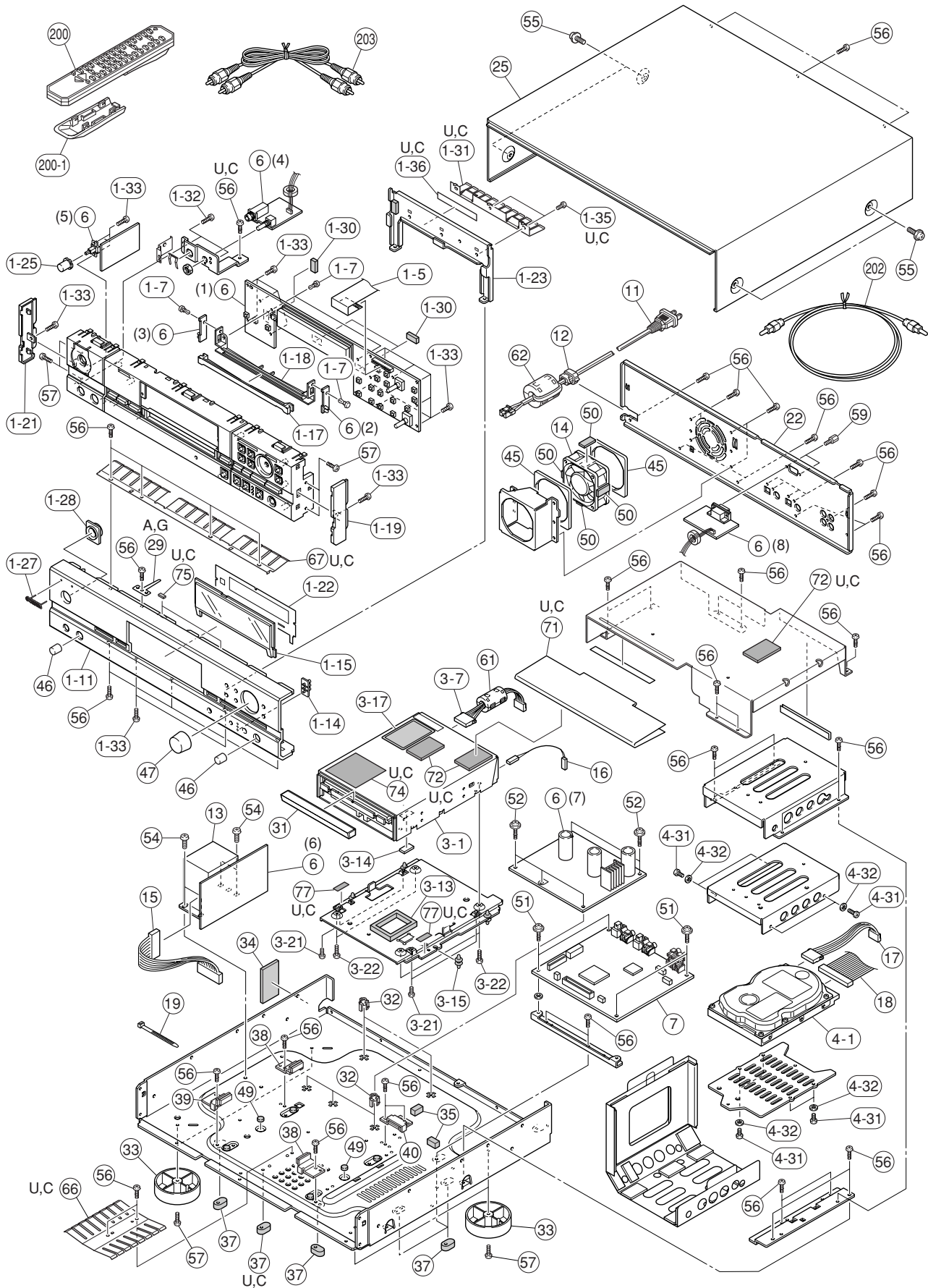

MECHANICAL PARTS

Ref. No.	PART NO.	Description	Remarks	Markets
*	1-5	V8463800 FLEXIBLE FLAT CABLE	25P	UC
*	1-5	V7986200 FLEXIBLE FLAT CABLE	25P 400mm P=1.25	AG
	1-7	VQ368600 PUSH RIVET	P3555-B	
*	1-11	V6665300 FRONT PANEL		BL
*	1-14	V6741300 LENS, LED		
*	1-15	V6741500 WINDOW PANEL, LID		
*	1-17	V7359800 REFLECTOR	PS	
*	1-18	V7416900 REFLECTOR/CASE		
*	1-19	V7416200 PLATE SIDE/R		BL
*	1-21	V7416500 PLATE SIDE/L		BL
*	1-22	V7416800 SHEET/DIFFUSION		
*	1-23	V8080100 PLATE/ASSY		
	1-25	V5914500 BUTTON/D12		BL
	1-27	V6034100 EMBLEM		BL
	1-28	V6094800 ESCUTCHEON/PW		BL
*	1-30	V8080300 DAMPER/FP		
*	1-31	V8146700 EARTH PLATE/CENTER		UC
	1-32	VN413300 BIND HEAD BONDING B-T. SCREW	3x8 MFZN2BL	
	1-33	EP600730 BIND HEAD P-TITE SCREW	3x8 MFC2BL	
	1-35	EP600410 BIND HEAD S-TITE SCREW	3x6 MFZN2Y	UC
*	1-36	V8458100 SHEET/A		UC
*	3-1	V7691100 CDR FINAL PRODUCT	CRW2100AML	
*	3-7	V7790200 CONNECTOR ASS'Y	4P 70mm C&C	
*	3-13	V6445800 PACKING/FFC		
*	3-14	V7276900 RADIATION SHEET	8x16	
*	3-15	V7881200 CUSHION/CDR		
*	3-17	V8147000 LABEL LASER CAUTION		
	3-21	V6534900 BIND HEAD S-TITE SCREW	2.6x5 MFZN2BL	
	3-22	EP620100 BIND HEAD P-TITE SCREW	2.6x8 MFZN2Y	
*	4-1	V8002000 HARD DISK DRIVE	3.50inch IC35L020	
*	4-31	VV452200 PAN HEAD SCREW	UN#6x32 MFZN2Y	
*	4-32	03765170 SPRING WASHER	4.0 #2	
*	6	V7455000 P.C.B. ASS'Y	OPERATION	
*	7	V7454900 P.C.B. ASS'Y	MAIN	
▲	11	V2363800 POWER CORD ASS'Y		UC
▲	11	V2296800 POWER CORD ASS'Y		A
▲	11	VN363700 POWER CORD ASS'Y		G
	12	V2438700 CORD STOPPER	10P1	
▲	13	X0211A00 POWER TRANSFORMER		UC
▲	13	X0212A00 POWER TRANSFORMER		A
* ▲	13	X0213A00 POWER TRANSFORMER		G
*	14	V7719700 DC FAN MOTOR	DC D06T-12TL07(EX)	
*	15	V7790700 CONNECTOR ASS'Y	10P 250mm C&C	
*	16	V7966200 CONNECTOR ASS'Y	2P 140mm C&C 2.5	
*	17	V7966300 CONNECTOR ASS'Y	4P 180mm C&C 3.96	
*	18	V7790800 CONNECTOR, FLAT CABLE	40P 430mm P=2.0	
	19	VU590000 BINDING TIE	CBTD001B	
*	22	V6636300 REAR PANEL		UC
*	22	V6675800 REAR PANEL		A
*	22	V6675900 REAR PANEL		G
	25	VZ876700 TOP COVER		BL
	29	VQ775900 GROUND PLATE		AG
*	31	V7418600 LID/ASSY		

* New Parts

Ref. No.	PART NO.	Description	Remarks	Markets
32	VR264400	SPACER	H8	
33	VQ780300	LEG	D60xH16	BL
* 34	V8001500	DAMPER/SIDE		
35	VQ390100	DAMPER	8x8x15	
* 37	V7993800	DAMPER/SCREW		
* 38	V7880200	STOPPER/A		
* 39	V7880300	STOPPER/B		
* 40	V7880400	STOPPER/C		
* 45	V8080500	CUSHION/FAN		
46	V6101000	KNOB HP		BL
* 47	V7357900	KNOB D26		BL
* 49	V7881000	DAMPER/D9		
* 50	V8080600	CUSHION	10x20	
51	VT669300	PW HEAD B-TITE SCREW	3x8-8 MFC2	
52	VT669400	PW HEAD B-TITE SCREW	3x15-8 MFC2	
54	V2728500	BIND HEAD S-TITE SCREW	4x7 MFZN2BL	
55	21991500	PW HEAD S-TITE SCREW	4x8-10 MFC2BL	BL
56	VN413300	BIND HEAD BONDING B-T. SCREW	3x8 MFZN2BL	
57	EP600250	BIND HEAD B-TITE SCREW	3x8 MFZN2Y	
59	V6509600	JACK SCREW	SS6-A47511848	
* 61	VY734700	FERRITE CORE	ZCAT2032-0930	
* 62	VV910400	FERRITE CORE	ZCAT3035-1330	
* 66	V8146500	EARTH PLATE/BOTTOM		UC
* 67	V8146600	EARTH PLATE/TOP		UC
* 71	V8457900	SHIELD/ATA		UC
* 72	V8393500	DAMPER	28x40	UC
* 74	V8458200	SHEET		UC
* 75	V8458300	DAMPER/EARTH		UC
* 77	V8393800	SPACER/TO.2		UC
		ACCESSORIES		
* 200	V7640500	REMOTE CONTROL TRANSMITTER	CDR3	RC7060-01-0025
200-1	AAX13340	LID	BLJYE 60050001	
202	V6326400	OPTICAL CABLE	1P 0.6m 1pc	
203	VY952200	PIN-PLUG CORD	2P 1.0m 1pc	
		BATTERY, MANGANESE	SUM-3,AA,R06	

* New Parts

Parts List for Carbon Resistors

Value	1/4W Type Part No.	1/6W Type Part No.	Value	1/4W Type Part No.	1/6W Type Part No.
1.0 Ω	HJ35 3100	HF85 3100	10 kΩ	HF45 7100	HF45 7100
1.8 Ω	HJ35 3180	*	11 kΩ	HF45 7110	HF45 7110
2.2 Ω	HJ35 3220	HF85 3220	12 kΩ	HJ35 7120	HF85 7120
3.3 Ω	HJ35 3330	HF85 3330	13 kΩ	HF45 7130	HF45 7130
4.7 Ω	HJ35 3470	HF85 3470	15 kΩ	HF45 7150	HF45 7150
5.6 Ω	HJ35 3560	HF85 3560	18 kΩ	HF45 7180	HF45 7180
10 Ω	HF45 4100	HF45 4100	22 kΩ	HF45 7220	HF45 7220
15 Ω	HJ35 4150	HF85 4150	24 kΩ	HF45 7240	HF45 7240
22 Ω	HF45 4220	HF45 4220	27 kΩ	HJ35 7270	HF85 7270
27 Ω	HJ35 4270	HF85 4270	30 kΩ	HF45 7300	HF45 7300
33 Ω	HF45 4330	HF45 4330	33 kΩ	HF45 7330	HF45 7330
39 Ω	HJ35 4470	HF85 4390	36 kΩ	HF45 7360	HF45 7360
47 Ω	HF45 4470	HF45 4470	39 kΩ	HF45 7390	HF45 7390
56 Ω	HF45 4560	HF45 4560	47 kΩ	HF45 7470	HF45 7470
68 Ω	HF45 4680	HF45 4680	51 kΩ	HF45 7510	HF45 7510
75 Ω	HF45 4750	HF45 4750	56 kΩ	HF45 7560	HF45 7560
82 Ω	HF45 4820	HF45 4820	62 kΩ	HF45 7620	HF45 7620
91 Ω	HF45 4910	HF45 4910	68 kΩ	HF45 7680	HF45 7680
100 Ω	HF45 5100	HF45 5100	82 kΩ	HF45 7820	HF45 7820
110 Ω	HJ35 5110	HF85 5110	91 kΩ	HF45 7910	HF45 7910
120 Ω	HF45 5120	HF45 5120	100 kΩ	HF45 8100	HF45 8100
150 Ω	HF45 5150	HF45 5150	110 kΩ	HF45 8110	HF45 8110
160 Ω	HJ35 5160	*	120 kΩ	HF45 8120	HF45 8120
180 Ω	HF45 5180	HF45 5180	150 kΩ	HF45 8150	HF45 8150
200 Ω	HF45 5200	HF45 5200	180 kΩ	HF45 8180	HF45 8180
220 Ω	HF45 5220	HF45 5220	220 kΩ	HJ35 8220	HF85 8220
270 Ω	HF45 5270	HF45 5270	270 kΩ	HF45 8270	HF45 8270
330 Ω	HF45 5330	HF45 5330	300 kΩ	HF45 8300	HF45 8300
390 Ω	HF45 5390	HF45 5390	330 kΩ	HF45 8330	HF45 8330
430 Ω	HF45 5430	HF45 5430	390 kΩ	HJ35 8390	HF85 8390
470 Ω	HF45 5470	HF45 5470	470 kΩ	HF45 8470	HF45 8470
510 Ω	HF45 5510	HF45 5510	560 kΩ	HJ35 8560	HF85 8560
560 Ω	HF45 5560	HF45 5560	680 kΩ	HJ35 8680	HF85 8680
680 Ω	HF45 5680	HF45 5680	820 kΩ	HJ35 8820	HF85 8820
820 Ω	HF45 5820	HF45 5820	1.0 MΩ	HF45 9100	HF45 9100
910 Ω	HF45 5910	HF45 5910	1.2 MΩ	HJ35 9120	*
1.0 kΩ	HF45 6100	HF45 6100	1.5 MΩ	HJ35 9150	HF85 9150
1.2 kΩ	HF45 6120	HF45 6120	1.8 MΩ	HJ35 9180	HF85 9180
1.5 kΩ	HF45 6150	HF45 6150	2.2 MΩ	HJ35 9220	HF85 9220
1.8 kΩ	HF45 6180	HF45 6180	3.3 MΩ	HJ35 9330	HF85 9330
2.0 kΩ	HJ35 6200	HF85 6200	3.9 MΩ	HJ35 9390	*
2.2 kΩ	HF45 6220	HF45 6220	4.7 MΩ	HJ35 9470	HF85 9470
2.4 kΩ	HJ35 6240	HF85 6240			
2.7 kΩ	HF45 6270	HF45 6270			
3.0 kΩ	HF45 6300	HF45 6300			
3.3 kΩ	HF45 6330	HF45 6330			
3.6 kΩ	HJ35 6360	HF85 6360			
3.9 kΩ	HF45 6390	HF45 6390			
4.7 kΩ	HF45 6470	HF45 6470			
5.1 kΩ	HF45 6510	HF45 6510			
5.6 kΩ	HF45 6560	HF45 6560			
6.8 kΩ	HF45 6680	HF45 6680			
8.2 kΩ	HF45 6820	HF45 6820			
9.1 kΩ	HF45 6910	HF45 6910			

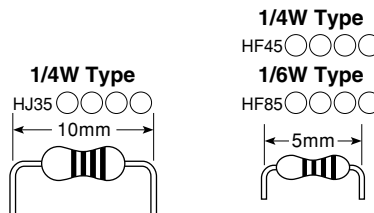

1/4W Type
HJ35 ○○○○
HF45 ○○○○

1/6W Type
HF85 ○○○○

REMOTE CONTROL TRANSMITTER

SCHEMATIC DIAGRAM

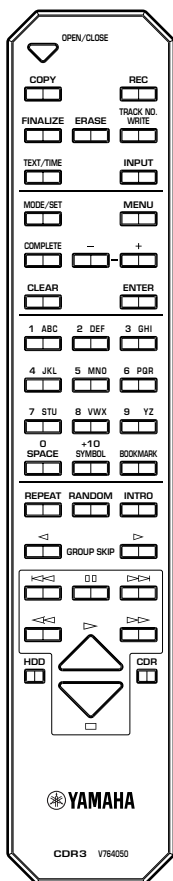
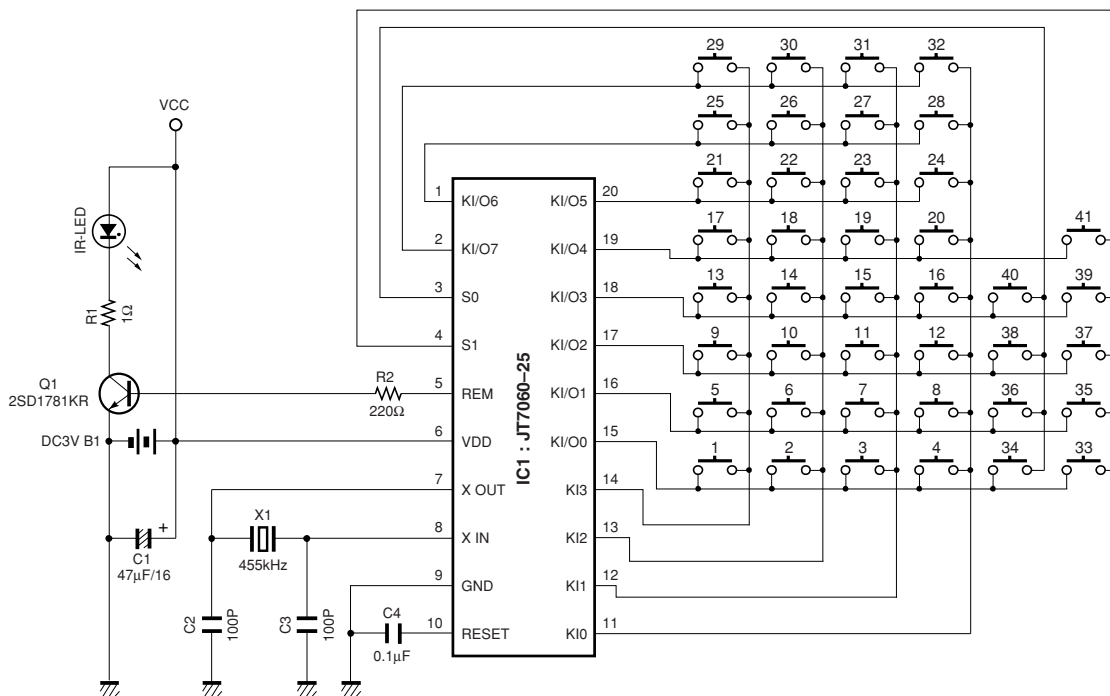

Key No.	Key Name	Custom Code (HEX)	Data Code (HEX)	Key No.	Key Name	Custom Code (HEX)	Data Code (HEX)
1	OPEN/CLOSE	7F	81	22	7 STU	7F	97
2	COPY	7F	A3	23	8 VWX	7F	98
3	REC	7F	A0	24	9 YZ	7F	99
4	FINALIZE	7F	A5	25	0/SPACE	7F	90
5	ERASE	7F	A6	26	+10/SYMBOL	7F	9A
6	TRACK NO. WRITE	7F	A7	27	BOOKMARK	7F	DD
7	TEXT/TIME	7F	9E	28	REPEAT	7F	8D
8	INPUT	7F	AB	29	RANDOM	7F	8E
9	MODE/SET	7F	B9	30	INTRO	7F	8F
10	MENU	7F	BA	31	◁ GROUP SKIP	7F	DE
11	COMPLETE	7F	B8	32	▷ GROUP SKIP	7F	DF
12	-	7F	BC	33	◀◀	7F	86
13	+	7F	BB	34	◻◻	7F	83
14	CLEAR	7F	8C	35	◻▶	7F	87
15	ENTER	7F	B7	36	◀◻	07	88
16	1 ABC	7F	91	37	▶	7F	82
17	2 DEF	7F	92	38	▶▶	7F	89
18	3 GHI	7F	93	39	HDD	7F	BE
19	4 JKL	7F	94	40	◻	7F	84
20	5 MNO	7F	95	41	CDR	7F	BD
21	6 PQR	7F	96				

CDR-HD1000

